

Biocalculus

Calculus, Probability, and Statistics
for the Life Sciences

About the Cover Images



The sex ratio of barred owl offspring is studied using probability theory in Exercise 12.3.21.

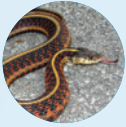

The fitness of a garter snake is a function of the degree of stripedness and the number of reversals of direction while fleeing a predator (Exercise 9.1.7).



The project on page 297 asks how birds can minimize power and energy by flapping their wings versus gliding.



Example 13.3.7 uses hypothesis testing to determine if infection by malaria causes mice to become anemic.

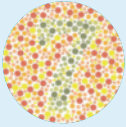

Color blindness is a genetically determined condition. Its inheritance in families is studied using conditional probability in Example 12.3.10.



Data from Gregor Mendel's famous genetic experiments with pea plants are used to introduce the techniques of descriptive statistics in Example 11.1.1.



The energy needed by an iguana to run is a function of two variables, weight and speed (Exercise 9.2.47).

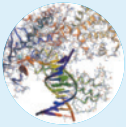

Our study of probability theory in Chapter 12 forms the basis for predicting the inheritance of genetic diseases such as Huntington's disease.



The project on page 222 illustrates how mathematics can be used to minimize red blood cell loss during surgery.

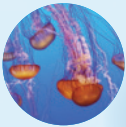

Jellyfish locomotion is modeled by a differential equation in Exercise 10.1.34.



The screw-worm fly was effectively eliminated using the sterile insect technique (Exercise 5.6.24).

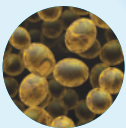

The growth of a yeast population leads naturally to the study of differential equations (Section 7.1).



The doubling time of a population of the bacterium *G. lamblia* is determined in Exercise 1.4.29.



Experimental data on EPO injection by athletes for performance enhancement are used in Chapter 13 to illustrate techniques of inferential statistics.



Data on the wingspan of Monarch butterflies are used in Example 13.1.6 to illustrate the importance of sampling distributions in inferential statistics.



The optimal foraging time for bumblebees is determined in Example 4.4.2.



The vertical trajectory of zebra finches is modeled by a quadratic function (Figure 1.2.8).



The size of the gray-wolf population depends on the size of the food supply and the number of competitors (Exercise 9.4.21).



Courtship displays by male ruby-throated hummingbirds provide an interesting example of a geometric random variable in Exercise 12.4.72.

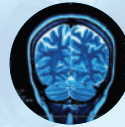

The area of a cross-section of a human brain is estimated in Exercise 6.Review.5.



The project on page 479 determines the critical vaccination coverage required to eradicate a disease.

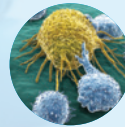

Natural killer cells attack pathogens and are found in two states described by a pair of differential equations developed in Section 10.3.



In Example 4.2.6 a junco has a choice of habitats with different seed densities and we determine the choice with the greatest energy reward.



Data on the number of ectoparasites of damselflies are studied in Exercise 11.1.9.

Biocalculus

Calculus, Probability, and Statistics
for the Life Sciences

James Stewart

McMaster University and University of Toronto

Troy Day

Queen's University



Australia • Brazil • Mexico • Singapore • United Kingdom • United States

This is an electronic version of the print textbook. Due to electronic rights restrictions, some third party content may be suppressed. Editorial review has deemed that any suppressed content does not materially affect the overall learning experience. The publisher reserves the right to remove content from this title at any time if subsequent rights restrictions require it. For valuable information on pricing, previous editions, changes to current editions, and alternate formats, please visit www.cengage.com/highered to search by ISBN#, author, title, or keyword for materials in your areas of interest.

Important Notice: Media content referenced within the product description or the product text may not be available in the eBook version.

**Biocalculus: Calculus, Probability, and Statistics
for the Life Sciences****James Stewart, Troy Day**

Product Manager: Neha Taleja

Senior Content Developer: Stacy Green

Associate Content Developer: Samantha Lughtu

Product Assistant: Stephanie Kreuz

Media Developer: Lynh Pham

Marketing Manager: Ryan Ahern

Content Project Manager: Cheryl Linthicum

Art Director: Vernon Boes

Manufacturing Planner: Becky Cross

Production Service and Composition: TECHarts

Text and Photo Researcher: Lumina Datamatics

Art and Copy Editor: Kathi Townes, TECHarts

Illustrator: TECHarts

Text and Cover Designer: Lisa Henry

Compositor: Stephanie Kuhns, TECHarts

Cover Images:

DNA strand © iStockphoto.com/Frank Ramspott; Junco © Steffen Foerster/Shutterstock.com; Barred owl © mlorenz/Shutterstock.com; Snake © Matt Jeppson/Shutterstock.com; Bird in flight © Targn Pleiades/Shutterstock.com; Red blood cells © DTKUTOO/Shutterstock.com; Ishihara test for color blindness © Eveleen/Shutterstock.com; Pea plant in bloom © yuris/Shutterstock.com; Iguana © Ryan Jackson; DNA polymerase I © Leonid Andronov/Shutterstock.com; Surgery © Condor 36/Shutterstock.com; Jellyfish © Dreamframer/Shutterstock.com; Srew-worm fly Courtesy of U.S. Department of Agriculture; Yeast cells © Knorre/Shutterstock.com; *G. lamblia* © Sebastian Kaulitzki/Shutterstock.com; Cyclist © encikat/Shutterstock.com; Monarch butterfly © Lightspring/Shutterstock.com; Bumblebee foraging © Miroslav Halama/Shutterstock.com; Bacteria rods © Fedorov Oleksiy/Shutterstock.com; Zebra finches © Wang LiQuiang/Shutterstock.com; Wolf © Vladimir Gramagin/Shutterstock.com; Hummingbird © Steve Byland/Shutterstock.com; Brain MRI © Allison Herreid/Shutterstock.com; Syringes © Tatikz2/Shutterstock.com; NK cells © Juan Gaertner/Shutterstock.com; Junco © Steffen Foerster/Shutterstock.com; Damsel fly © Laura Nagel; Wolves © Vladimir Gramagin/Shutterstock.com; Snake © Matt Jeppson/Shutterstock.com; Background gradient © ririro/Shutterstock.com

Interior design images:

Pills © silver-john/Shutterstock.com;

Daphnia pulex © Lebendkulturen.de/Shutterstock.com

© 2016 Cengage Learning

WCN: 02-200-203

ALL RIGHTS RESERVED. No part of this work covered by the copyright herein may be reproduced, transmitted, stored, or used in any form or by any means graphic, electronic, or mechanical, including but not limited to photocopying, recording, scanning, digitizing, taping, Web distribution, information networks, or information storage and retrieval systems, except as permitted under Section 107 or 108 of the 1976 United States Copyright Act, without the prior written permission of the publisher.

For product information and technology assistance, contact us at
Cengage Learning Customer & Sales Support, 1-800-354-9706.

For permission to use material from this text or product,
submit all requests online at www.cengage.com/permissions.

Further permissions questions can be e-mailed to
permissionrequest@cengage.com.

Library of Congress Control Number: 2015942360

ISBN-13: 978-1-305-11403-6

Cengage Learning

20 Channel Center Street

Boston, MA 02210

USA

Cengage Learning is a leading provider of customized learning solutions with employees residing in nearly 40 different countries and sales in more than 125 countries around the world. Find your local representative at www.cengage.com.

Cengage Learning products are represented in Canada by
Nelson Education, Ltd.

To learn more about Cengage Learning Solutions, visit www.cengage.com.
Purchase any of our products at your local college store or at our preferred
online store www.cengagebrain.com.

Windows is a registered trademark of the Microsoft Corporation and used
herein under license.

Macintosh and Power Macintosh are registered trademarks of Apple Com-
puter, Inc. Used herein under license.

Derive is a registered trademark of Soft Warehouse, Inc.

Maple is a registered trademark of Waterloo Maple, Inc.

Mathematica is a registered trademark of Wolfram Research, Inc.

Tools for Enriching Calculus is a trademark used herein under license.

Printed in the United States of America

Print Number: 01 Print Year: 2015

To Dolph Schluter and Don Ludwig, for early inspiration

About the Authors

JAMES STEWART received the M.S. degree from Stanford University and the Ph.D. from the University of Toronto. After two years as a postdoctoral fellow at the University of London, he became Professor of Mathematics at McMaster University. His research has been in harmonic analysis and functional analysis. Stewart's books include a series of high-school textbooks as well as a best-selling series of calculus textbooks published by Cengage Learning. He is also coauthor, with Lothar Redlin and Saleem Watson, of a series of college algebra and precalculus textbooks. Translations of his books include those into Spanish, Portuguese, French, Italian, Korean, Chinese, Greek, Indonesian, and Japanese.

A talented violinist, Stewart was concertmaster of the McMaster Symphony Orchestra for many years and played professionally in the Hamilton Philharmonic Orchestra. He has given more than 20 talks worldwide on Mathematics and Music.

Stewart was named a Fellow of the Fields Institute in 2002 and was awarded an honorary D.Sc. in 2003 by McMaster University. The library of the Fields Institute is named after him. The James Stewart Mathematics Centre was opened in October, 2003, at McMaster University.

TROY DAY received the M.S. degree in biology from the University of British Columbia and the Ph.D. in mathematics from Queen's University. His first academic position was at the University of Toronto, before being recruited back to Queen's University as a Canada Research Chair in Mathematical Biology. He is currently Professor of Mathematics and Statistics and Professor of Biology. His research group works in areas ranging from applied mathematics to experimental biology. Day is also coauthor of the widely used book *A Biologist's Guide to Mathematical Modeling*, published by Princeton University Press in 2007.

Contents

Preface	xv
To the Student	xxv
Calculators, Computers, and Other Graphing Devices	xxvi
Diagnostic Tests	xxviii
Prologue: Mathematics and Biology	xxxiii
Case Studies in Mathematical Modeling	xli
CASE STUDY 1 Kill Curves and Antibiotic Effectiveness	xlii
CASE STUDY 2 Hosts, Parasites, and Time-Travel	xlvi

1 Functions and Sequences 1

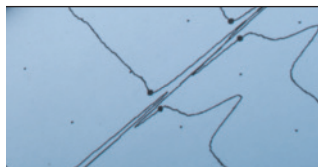

1.1 Four Ways to Represent a Function	2		
▪ Representations of Functions	▪ Piecewise Defined Functions	▪ Symmetry	
▪ Periodic Functions	▪ Increasing and Decreasing Functions		
1.2 A Catalog of Essential Functions	17		
▪ Linear Models	▪ Polynomials	▪ Power Functions	▪ Rational Functions
▪ Algebraic Functions	▪ Trigonometric Functions	▪ Exponential Functions	
▪ Logarithmic Functions			
1.3 New Functions from Old Functions	31		
▪ Transformations of Functions	▪ Combinations of Functions		
PROJECT The Biomechanics of Human Movement	40		
1.4 Exponential Functions	41		
▪ The Growth of Malarial Parasites	▪ Exponential Functions	▪ Exponential Growth	
▪ HIV Density and Exponential Decay	▪ The Number e		
1.5 Logarithms; Semilog and Log-Log Plots	52		
▪ Inverse Functions	▪ Logarithmic Functions	▪ Natural Logarithms	
▪ Graph and Growth of the Natural Logarithm	▪ Semilog Plots	▪ Log-Log Plots	
PROJECT The Coding Function of DNA	69		
1.6 Sequences and Difference Equations	70		
▪ Recursive Sequences: Difference Equations			
▪ Discrete-Time Models in the Life Sciences			
PROJECT Drug Resistance in Malaria	78		
Review	80		
CASE STUDY 1a Kill Curves and Antibiotic Effectiveness	84		

2 Limits 89

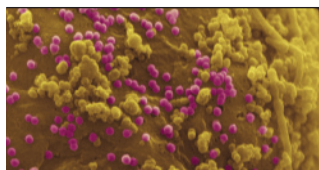

2.1 Limits of Sequences 90

- The Long-Term Behavior of a Sequence
- Definition of a Limit
- Limit Laws
- Geometric Sequences
- Recursion for Medication
- Geometric Series
- The Logistic Sequence in the Long Run

PROJECT Modeling the Dynamics of Viral Infections 101

2.2 Limits of Functions at Infinity 102

- The Monod Growth Function
- Definition of a Limit at Infinity
- Limits Involving Exponential Functions
- Infinite Limits at Infinity

2.3 Limits of Functions at Finite Numbers 111

- Velocity Is a Limit
- Limits: Numerical and Graphical Methods
- One-Sided Limits
- Infinite Limits

2.4 Limits: Algebraic Methods 125

- The Limit Laws
- Additional Properties of Limits
- Limits of Trigonometric Functions

2.5 Continuity 137

- Definition of a Continuous Function
- Which Functions Are Continuous?
- Approximating Discontinuous Functions by Continuous Ones

Review 149

CASE STUDY 2a Hosts, Parasites, and Time-Travel 151

3 Derivatives 155

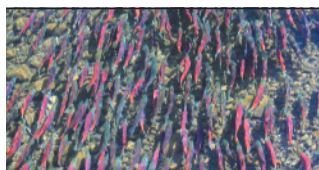

3.1 Derivatives and Rates of Change 156

- Measuring the Rate of Increase of Blood Alcohol Concentration
- Tangent Lines
- Derivatives
- Rates of Change

3.2 The Derivative as a Function 168

- Graphing a Derivative from a Function's Graph
- Finding a Derivative from a Function's Formula
- Differentiability
- Higher Derivatives
- What a Derivative Tells Us about a Function

3.3 Basic Differentiation Formulas 181

- Power Functions
- New Derivatives from Old
- Exponential Functions
- Sine and Cosine Functions

3.4 The Product and Quotient Rules 194

- The Product Rule
- The Quotient Rule
- Trigonometric Functions

3.5 The Chain Rule 202

- Combining the Chain Rule with Other Rules
- Exponential Functions with Arbitrary Bases
- Longer Chains
- Implicit Differentiation
- Related Rates
- How To Prove the Chain Rule

- 3.6 Exponential Growth and Decay 215**
- Population Growth
 - Radioactive Decay
 - Newton's Law of Cooling
- PROJECT:** Controlling Red Blood Cell Loss During Surgery 222
- 3.7 Derivatives of the Logarithmic and Inverse Tangent Functions 222**
- Differentiating Logarithmic Functions
 - Logarithmic Differentiation
 - The Number e as a Limit
 - Differentiating the Inverse Tangent Function
- 3.8 Linear Approximations and Taylor Polynomials 230**
- Tangent Line Approximations
 - Newton's Method
 - Taylor Polynomials
- PROJECT:** Harvesting Renewable Resources 239
- Review 240**
- CASE STUDY 1b** Kill Curves and Antibiotic Effectiveness 245

4 Applications of Derivatives 249

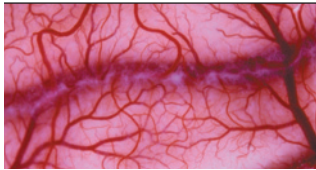

- 4.1 Maximum and Minimum Values 250**
- Absolute and Local Extreme Values
 - Fermat's Theorem
 - The Closed Interval Method
- PROJECT:** The Calculus of Rainbows 259
- 4.2 How Derivatives Affect the Shape of a Graph 261**
- The Mean Value Theorem
 - Increasing and Decreasing Functions
 - Concavity
 - Graphing with Technology
- 4.3 L'Hospital's Rule: Comparing Rates of Growth 274**
- Indeterminate Quotients
 - Which Functions Grow Fastest?
 - Indeterminate Products
 - Indeterminate Differences
- PROJECT:** Mutation-Selection Balance in Genetic Diseases 284
- 4.4 Optimization Problems 285**
- PROJECT:** Flapping and Gliding 297
- PROJECT:** The Tragedy of the Commons: An Introduction to Game Theory 298
- 4.5 Recursions: Equilibria and Stability 299**
- Equilibria
 - Cobwebbing
 - Stability Criterion
- 4.6 Antiderivatives 306**
- Review 312**

5 Integrals 315

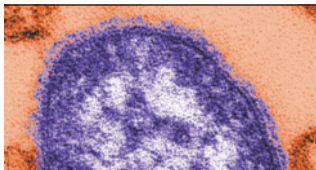

- 5.1 Areas, Distances, and Pathogenesis 316**
- The Area Problem
 - The Distance Problem
 - Pathogenesis
- 5.2 The Definite Integral 329**
- Calculating Integrals
 - The Midpoint Rule
 - Properties of the Definite Integral

5.3 The Fundamental Theorem of Calculus 342
 ■ Evaluating Definite Integrals ■ Indefinite Integrals ■ The Net Change Theorem
 ■ The Fundamental Theorem ■ Differentiation and Integration as Inverse Processes
PROJECT: The Outbreak Size of an Infectious Disease 354

5.4 The Substitution Rule 354
 ■ Substitution in Indefinite Integrals ■ Substitution in Definite Integrals ■ Symmetry

5.5 Integration by Parts 362
 ■ Indefinite Integrals ■ Definite Integrals

5.6 Partial Fractions 368

5.7 Integration Using Tables and Computer Algebra Systems 371
 ■ Tables of Integrals ■ Computer Algebra Systems
 ■ Can We Integrate All Continuous Functions?

5.8 Improper Integrals 376
 Review 381

CASE STUDY 1c Kill Curves and Antibiotic Effectiveness 385

6 Applications of Integrals 387

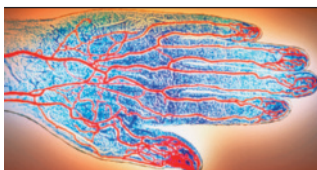

6.1 Areas Between Curves 388
 ■ Cerebral Blood Flow
PROJECT: Disease Progression and Immunity 394
PROJECT: The Gini Index 395

6.2 Average Values 397

6.3 Further Applications to Biology 400
 ■ Survival and Renewal ■ Blood Flow ■ Cardiac Output

6.4 Volumes 405
 Review 412

CASE STUDY 1d Kill Curves and Antibiotic Effectiveness 414
CASE STUDY 2b Hosts, Parasites, and Time-Travel 416

7 Differential Equations 419

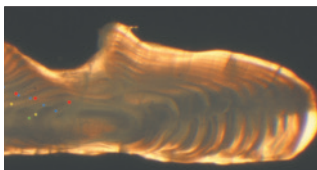

7.1 Modeling with Differential Equations 420
 ■ Models of Population Growth
 ■ Classifying Differential Equations
PROJECT: Chaotic Blowflies and the Dynamics of Populations 430

- 7.2 Phase Plots, Equilibria, and Stability 431**
- Phase Plots ▪ Equilibria and Stability
 - A Mathematical Derivation of the Local Stability Criterion
- PROJECT:** Catastrophic Population Collapse:
An Introduction to Bifurcation Theory 438
- 7.3 Direction Fields and Euler’s Method 440**
- Direction Fields ▪ Euler’s Method
- 7.4 Separable Equations 449**
- PROJECT:** Why Does Urea Concentration Rebound after Dialysis? 458
- 7.5 Systems of Differential Equations 459**
- Parametric Curves ▪ Systems of Two Autonomous Differential Equations
- PROJECT:** The Flight Path of Hunting Raptors 467
- 7.6 Phase Plane Analysis 468**
- Equilibria ▪ Qualitative Dynamics in the Phase Plane
- PROJECT:** Determining the Critical Vaccination Coverage 479
- Review 480**
- CASE STUDY 2c** Hosts, Parasites, and Time-Travel 484

8 Vectors and Matrix Models 487

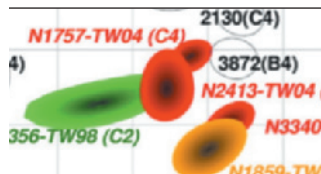

- 8.1 Coordinate Systems 488**
- Three-Dimensional Space ▪ Higher-Dimensional Space
- 8.2 Vectors 496**
- Combining Vectors ▪ Components
- 8.3 The Dot Product 505**
- Projections
- PROJECT:** Microarray Analysis of Genome Expression 513
- PROJECT:** Vaccine Escape 514
- 8.4 Matrix Algebra 514**
- Matrix Notation ▪ Matrix Addition and Scalar Multiplication ▪ Matrix Multiplication
- 8.5 Matrices and the Dynamics of Vectors 520**
- Systems of Difference Equations: Matrix Models ▪ Leslie Matrices ▪ Summary
- 8.6 The Inverse and Determinant of a Matrix 528**
- The Inverse of a Matrix ▪ The Determinant of a Matrix
 - Solving Systems of Linear Equations
- PROJECT:** Cubic Splines 536
- 8.7 Eigenvectors and Eigenvalues 537**
- Characterizing How Matrix Multiplication Changes Vectors
 - Eigenvectors and Eigenvalues

- 8.8 Iterated Matrix Models 547**
- Solving Matrix Models
 - Solutions with Complex Eigenvalues
 - Perron-Frobenius Theory
- PROJECT:** The Emergence of Geometric Order in Proliferating Cells 559
- Review 560**

9 Multivariable Calculus 565

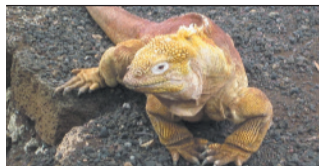

- 9.1 Functions of Several Variables 566**
- Functions of Two Variables
 - Graphs
 - Level Curves
 - Functions of Three Variables
 - Limits and Continuity
- 9.2 Partial Derivatives 585**
- Interpretations of Partial Derivatives
 - Functions of More Than Two Variables
 - Higher Derivatives
 - Partial Differential Equations
- 9.3 Tangent Planes and Linear Approximations 596**
- Tangent Planes
 - Linear Approximations
- PROJECT:** The Speedo LZR Racer 603
- 9.4 The Chain Rule 604**
- Implicit Differentiation
- 9.5 Directional Derivatives and the Gradient Vector 610**
- Directional Derivatives
 - The Gradient Vector
 - Maximizing the Directional Derivative
- 9.6 Maximum and Minimum Values 619**
- Absolute Maximum and Minimum Values
- Review 628**

10 Systems of Linear Differential Equations 631



- 10.1 Qualitative Analysis of Linear Systems 632**
- Terminology
 - Saddles
 - Nodes
 - Spirals
- 10.2 Solving Systems of Linear Differential Equations 640**
- The General Solution
 - Nullclines versus Eigenvectors
 - Saddles
 - Nodes
 - Spirals
 - Long-Term Behavior
- 10.3 Applications 652**
- Metapopulations
 - Natural Killer Cells and Immunity
 - Gene Regulation
 - Transport of Environmental Pollutants
- PROJECT:** Pharmacokinetics of Antimicrobial Dosing 664
- 10.4 Systems of Nonlinear Differential Equations 665**
- Linear and Nonlinear Differential Equations
 - Local Stability Analyses
 - Linearization
 - Examples
- Review 676**

CASE STUDY 2d: Hosts, Parasites, and Time-Travel 679

11 Descriptive Statistics 683



11.1 Numerical Descriptions of Data 684

- Types of Variables
- Categorical Data
- Numerical Data: Measures of Central Tendency
- Numerical Data: Measures of Spread
- Numerical Data: The Five-Number Summary
- Outliers

11.2 Graphical Descriptions of Data 693

- Displaying Categorical Data
- Displaying Numerical Data: Histograms
- Interpreting Area in Histograms
- The Normal Curve

11.3 Relationships between Variables 703

- Two Categorical Variables
- Categorical and Numerical Variables
- Two Numerical Variables

11.4 Populations, Samples, and Inference 713

- Populations and Samples
- Properties of Samples
- Types of Data
- Causation

PROJECT: The Birth Weight Paradox 720

Review 722

12 Probability 727

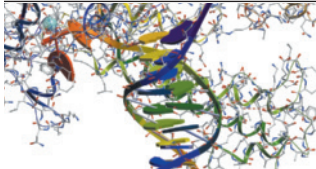

12.1 Principles of Counting 728

- Permutations
- Combinations

12.2 What Is Probability? 737

- Experiments, Trials, Outcomes, and Events
- Probability When Outcomes Are Equally Likely
- Probability in General

12.3 Conditional Probability 751

- Conditional Probability
- The Multiplication Rule and Independence
- The Law of Total Probability
- Bayes' Rule

PROJECT: Testing for Rare Diseases 766

12.4 Discrete Random Variables 767

- Describing Discrete Random Variables
- Mean and Variance of Discrete Random Variables
- Bernoulli Random Variables
- Binomial Random Variables

PROJECT: DNA Supercoiling 783

PROJECT: The Probability of an Avian Influenza Pandemic in Humans 784

12.5 Continuous Random Variables 786

- Describing Continuous Random Variables
- Mean and Variance of Continuous Random Variables
- Exponential Random Variables
- Normal Random Variables

Review 799

13 Inferential Statistics 803



- 13.1 The Sampling Distribution 804**
 - Sums of Random Variables
 - The Sampling Distribution of the Mean
 - The Sampling Distribution of the Standard Deviation
- 13.2 Confidence Intervals 812**
 - Interval Estimates
 - Student's t -Distribution
- 13.3 Hypothesis Testing 821**
 - The Null and Alternative Hypotheses
 - The t -Statistic
 - The P -Value
 - Summary
- 13.4 Contingency Table Analysis 829**
 - Hypothesis Testing with Contingency Tables
 - The Chi-Squared Test Statistic
 - The Hypothesis Test
 - Summary
- Review 835**

APPENDIXES 839

- A Intervals, Inequalities, and Absolute Values 840**
- B Coordinate Geometry 845**
- C Trigonometry 855**
- D Precise Definitions of Limits 864**
- E A Few Proofs 870**
- F Sigma Notation 874**
- G Complex Numbers 880**
- H Statistical Tables 888**

GLOSSARY OF BIOLOGICAL TERMS 891

ANSWERS TO ODD-NUMBERED EXERCISES 893

BIOLOGICAL INDEX 947

INDEX 957

Preface

In recent years more and more colleges and universities have been introducing calculus courses specifically for students in the life sciences. This reflects a growing recognition that mathematics has become an indispensable part of any comprehensive training in the biological sciences.

Our chief goal in writing this textbook is to show students how calculus relates to biology. We motivate and illustrate the topics of calculus with examples drawn from many areas of biology, including genetics, biomechanics, medicine, pharmacology, physiology, ecology, epidemiology, and evolution, to name a few. We have paid particular attention to ensuring that all applications of the mathematics are genuine, and we provide references to the primary biological literature for many of these so that students and instructors can explore the applications in greater depth.

We strive for a style that maintains rigor without being overly formal. Although our focus is on the interface between mathematics and the life sciences, the logical structure of the book is motivated by the mathematical material. Students will come away from a course based on this book with a sound knowledge of mathematics and an understanding of the importance of mathematical arguments. Equally important, they will also come away with a clear understanding of how these mathematical concepts and techniques are central in the life sciences, just as they are in physics, chemistry, and engineering.

The book begins with a prologue entitled *Mathematics and Biology* detailing how the applications of mathematics to biology have proliferated over the past several decades and giving a preview of some of the ways in which calculus provides insight into biological phenomena.

Alternate Versions

There are two versions of this textbook. The first is entitled *Biocalculus: Calculus for the Life Sciences*; it focuses on calculus and some elements of linear algebra that are important in the life sciences. This is the second version, entitled *Biocalculus: Calculus, Probability, and Statistics for the Life Sciences*; it contains all of the content of the first version as well as three additional chapters titled *Descriptive Statistics*, *Probability*, and *Inferential Statistics* (see Content on page xviii).

Features

■ Real-World Data

We think it's important for students to see and work with real-world data in both numerical and graphical form. Accordingly, we have used data concerning biological phenomena to introduce, motivate, and illustrate the concepts of calculus. Many of the examples and exercises deal with functions defined by such numerical data or graphs. See, for example, Figure 1.1.1 (electrocardiogram), Figure 1.1.23 (malarial fever), Exercise 1.1.26 (blood alcohol concentration), Table 2 in Section 1.4 (HIV density), Table 3 in Section 1.5 (species richness in bat caves), Example 3.1.7 (growth of malarial parasites),

Exercise 3.1.42 (salmon swimming speed), Exercises 4.1.7–8 (influenza pandemic), Exercise 4.2.10 (HIV prevalence), Figure 5.1.17 (measles pathogenesis), Exercise 5.1.11 (SARS incidence), Figure 6.1.8 and Example 6.1.4 (cerebral blood flow), Table 1 and Figure 1 in Section 7.1 (yeast population), Figure 8.1.14 (antigenic cartography), Exercises 9.1.7, 9.2.48, and Examples 9.5.5 and 9.6.6 (snake reversals and stripes). And, of course, Chapters 11 and 13 are focused entirely on the analysis of biological data.

■ Graded Exercise Sets

Each exercise set is carefully graded, progressing from basic conceptual exercises and skill-development problems to more challenging problems involving applications and proofs.

■ Conceptual Exercises

One of the goals of calculus instruction is conceptual understanding, and the most important way to foster conceptual understanding is through the problems that we assign. To that end we have devised various types of problems. Some exercise sets begin with requests to explain the meanings of the basic concepts of the section. (See, for instance, the first few exercises in Sections 2.3, 2.5, 3.3, 4.1, and 8.2.) Similarly, all the review sections begin with a Concept Check and a True-False Quiz. Other exercises test conceptual understanding through graphs or tables (see Exercises 3.1.11, 5.2.41–43, 7.1.9–11, 9.1.1–2, and 9.1.26–32).

Another type of exercise uses verbal description to test conceptual understanding (see Exercises 2.5.12, 3.2.50, 4.3.47, and 5.8.29).

■ Projects

One way of involving students and making them active learners is to have them work (perhaps in groups) on extended projects that give a feeling of substantial accomplishment when completed. We have provided 24 projects in *Biocalculus: Calculus for the Life Sciences* and an additional four in *Biocalculus: Calculus, Probability, and Statistics for the Life Sciences*. *Drug Resistance in Malaria* (page 78), for example, asks students to construct a recursion for the frequency of the gene that causes resistance to an anti-malarial drug. The project *Flapping and Gliding* (page 297) asks how birds can minimize power and energy by flapping their wings versus gliding. In *The Tragedy of the Commons: An Introduction to Game Theory* (page 298), two companies are exploiting the same fish population and students determine optimal fishing efforts. The project *Disease Progression and Immunity* (page 394) is a nice application of areas between curves. *DNA Supercoiling* (page 783) uses ideas from probability theory to predict how DNA is coiled and compacted into cells. We think that, even when projects are not assigned, students might well be intrigued by them when they come across them between sections.

■ Case Studies



We also provide two case studies: (1) *Kill Curves and Antibiotic Effectiveness* and (2) *Hosts, Parasites, and Time-Travel*. These are extended real-world applications from the primary literature that are more involved than the projects and that tie together multiple mathematical ideas throughout the book. An introduction to each case study is provided at the beginning of the book (page xli), and then each case study recurs in various chapters as the student learns additional mathematical techniques. The case studies can be used at the beginning of a course as motivation for learning the mathematics, and they can then be returned to throughout the course as they recur in the textbook. Alternatively,

a case study may be assigned at the end of a course so students can work through all components of the case study in its entirety once all of the mathematical ideas are in place. Case studies might also be assigned to students as term projects. Additional case studies will be posted on the website www.stewartcalculus.com as they become available.

■ Biology Background

Although we give the biological background for each of the applications throughout the textbook, it is sometimes useful to have additional information about how the biological phenomenon was translated into the language of mathematics. In order to maintain a clear and logical flow of the mathematical ideas in the text, we have therefore included such information, along with animations, further references, and downloadable data on the website www.stewartcalculus.com. Applications for which such additional information is available are marked with the icon  in the text.

■ Technology

The availability of technology makes it more important to clearly understand the concepts that underlie the images on the screen. But, when properly used, graphing calculators and computers are powerful tools for discovering and understanding those concepts. (See the section *Calculators, Computers, and Other Graphing Devices* on page xxvi for a discussion of these and other computing devices.) These textbooks can be used either with or without technology and we use two special symbols to indicate clearly when a particular type of machine is required. The icon  indicates an exercise that definitely requires the use of such technology, but that is not to say that it can't be used on the other exercises as well. The symbol  is reserved for problems in which the full resources of a computer algebra system (like Maple, Mathematica, or the TI-89/92) are required. But technology doesn't make pencil and paper obsolete. Hand calculation and sketches are often preferable to technology for illustrating and reinforcing some concepts. Both instructors and students need to develop the ability to decide where the hand or the machine is appropriate.

■ Tools for Enriching Calculus (TEC)

TEC is a companion to the text and is intended to enrich and complement its contents. (It is now accessible in Enhanced WebAssign and CengageBrain.com. Selected Visuals and Modules are available at www.stewartcalculus.com.) Developed in collaboration with Harvey Keynes, Dan Clegg, and Hubert Hohn, TEC uses a discovery and exploratory approach. In sections of the book where technology is particularly appropriate, marginal icons  direct students to TEC Visuals and Modules that provide a laboratory environment in which they can explore the topic in different ways and at different levels. **Visuals are animations of figures in text; Modules are more elaborate activities and include exercises.** Instructors can choose to become involved at several different levels, ranging from simply encouraging students to use the Visuals and Modules for independent exploration, to assigning specific exercises from those included with each Module, to creating additional exercises, labs, and projects that make use of the Visuals and Modules.

■ Enhanced WebAssign

Technology is having an impact on the way homework is assigned to students, particularly in large classes. The use of online homework is growing and its appeal depends on ease of use, grading precision, and reliability. We have been working with the calculus

community and WebAssign to develop a robust online homework system. Up to 50% of the exercises in each section are assignable as online homework, including free response, multiple choice, and multi-part formats.

The system also includes *Active Examples*, in which students are guided in step-by-step tutorials through text examples, with links to the textbook and to video solutions. The system features a customizable *YouBook*, a *Show My Work* feature, *Just in Time* review of precalculus prerequisites, an *Assignment Editor*, and an *Answer Evaluator* that accepts mathematically equivalent answers and allows for homework grading in much the same way that an instructor grades.

■ Website

The site www.stewartcalculus.com includes the following.

- Algebra Review
- Lies My Calculator and Computer Told Me
- History of Mathematics, with links to the better historical websites
- Additional Topics (complete with exercise sets): Approximate Integration: The Trapezoidal Rule and Simpson's Rule, First-Order Linear Differential Equations, Second-Order Linear Differential Equations, Double Integrals, Infinite Series, and Fourier Series
- Archived Problems (drill exercises and their solutions)
- Challenge Problems
- Links, for particular topics, to outside Web resources
- Selected Tools for Enriching Calculus (TEC) Modules and Visuals
- Case Studies
- Biology Background material, denoted by the icon **BB** in the text
- Data sets

Content

Diagnostic Tests The books begin with four diagnostic tests, in Basic Algebra, Analytic Geometry, Functions, and Trigonometry.

Prologue This is an essay entitled *Mathematics and Biology*. It details how the applications of mathematics to biology have proliferated over the past several decades and highlights some of the applications that will appear throughout the book.

Case Studies The case studies are introduced here so that they can be used as motivation for learning the mathematics. Each case study then recurs at the ends of various chapters throughout the book.

1 Functions and Sequences The first three sections are a review of functions from precalculus, but in the context of biological applications. Sections 1.4 and 1.5 review exponential and logarithmic functions; the latter section includes semilog and log-log plots because of their importance in the life sciences. The final section introduces sequences at a much earlier stage than in most calculus books. Emphasis is placed on recursive sequences, that is, difference equations, allowing us to discuss discrete-time models in the biological sciences.

2 Limits We begin with limits of sequences as a follow-up to their introduction in Section 1.6. We feel that the basic idea of a limit is best understood in the context of sequences. Then it makes sense to follow with the limit of a function at infinity, which we present in the setting of the Monod growth function. Then we consider limits of functions at finite numbers, first geometrically and numerically, then algebraically. (The precise definition is given in Appendix D.) Continuity is illustrated by population harvesting and collapse.

3 Derivatives Derivatives are introduced in the context of rate of change of blood alcohol concentration and tangent lines. All the basic functions, including the exponential and logarithmic functions, are differentiated here. When derivatives are computed in applied settings, students are asked to explain their meanings.

4 Applications of Derivatives The basic facts concerning extreme values and shapes of curves are deduced using the Mean Value Theorem as the starting point. In the section on l'Hospital's Rule we use it to compare rates of growth of functions. Among the applications of optimization, we investigate foraging by bumblebees and aquatic birds. The Stability Criterion for Recursive Sequences is justified intuitively and a proof based on the Mean Value Theorem is given in Appendix E.

5 Integrals The definite integral is motivated by the area problem, the distance problem, and the measles pathogenesis problem. (The area under the pathogenesis curve up to the time symptoms occur is equal to the total amount of infection needed to develop symptoms.) Emphasis is placed on explaining the meanings of integrals in various contexts and on estimating their values from graphs and tables. There is no separate chapter on techniques of integration, but substitution and parts are covered here, as well as the simplest cases of partial fractions.

6 Applications of Integrals The Kety-Schmidt method for measuring cerebral blood flow is presented as an application of areas between curves. Other applications include the average value of a fish population, blood flow in arteries, the cardiac output of the heart, and the volume of a liver.

7 Differential Equations Modeling is the theme that unifies this introductory treatment of differential equations. The chapter begins by constructing a model for yeast population size as a way to motivate the formulation of differential equations. We then show how phase plots allow us to gain considerable qualitative information about the behavior of differential equations; phase plots also provide a simple introduction to bifurcation theory. Examples range from cancer progression to individual growth, to ecology, to anesthesiology. Direction fields and Euler's method are then studied before separable equations are solved explicitly, so that qualitative, numerical, and analytical approaches are given equal consideration. The final two sections of this chapter explore systems of two differential equations. This brief introduction is given here because it allows students to see some applications of systems of differential equations without requiring any additional mathematical preparation. A more complete treatment is then given in Chapter 10.

8 Vectors and Matrix Models We start by introducing higher-dimensional coordinate systems and their applications in the life sciences including antigenic cartography and genome expression profiles. Vectors are then introduced, along with the dot product, and these are shown to provide insight ranging from influenza epidemiology, to cardiology, to vaccine escape, to the discovery of new biological compounds. They also provide some of the tools necessary for the treatment of multivariable calculus in Chapter 9. The remainder of this chapter is then devoted to the application of further ideas from linear algebra to biology. A brief introduction to matrix algebra is followed by a section where these ideas are used to model many different biological phenomena with the aid of matrix diagrams. The final three sections are devoted to the mathematical analysis of

such models. This includes a treatment of eigenvalues and eigenvectors, which will also be needed as preparation for Chapter 10, and a treatment of the long-term behavior of matrix models using Perron-Frobenius Theory.

9 Multivariable Calculus Partial derivatives are introduced by looking at a specific column in a table of values of the heat index (perceived air temperature) as a function of the actual temperature and the relative humidity. Applications include body mass index, infectious disease control, lizard energy expenditure, and removal of urea from the blood in dialysis. If there isn't time to cover the entire chapter, then it would make sense to cover just sections 9.1 and 9.2 (preceded by 8.1) and perhaps 9.6. But if Section 9.5 is covered, then Sections 8.2 and 8.3 are prerequisites.

10 Systems of Linear Differential Equations Again modeling is the theme that unifies this chapter. Systems of linear differential equations enjoy very wide application in the life sciences and they also form the basis for the study of systems of nonlinear differential equations. To aid in visualization we focus on two-dimensional systems, and we begin with a qualitative exploration of the different sorts of behaviors that are possible in the context of population dynamics and radioimmunotherapy. The general solution to two-dimensional systems is then derived with the use of eigenvalues and eigenvectors. The third section then illustrates these results with four extended applications involving metapopulations, the immune system, gene regulation, and the transport of environmental pollutants. The chapter ends with a section that shows how the ideas from systems of linear differential equations can be used to understand local stability properties of equilibria in systems of nonlinear differential equations. To cover this chapter students will first need sections 8.1–8.4 and 8.6–8.7.

11 Descriptive Statistics Statistical analyses are central in most areas of biology. The basic ideas of descriptive statistics are presented here, including types of variables, measures of central tendency and spread, and graphical descriptions of data. Single variables are treated first, followed by an examination of the descriptive statistics for relationships between variables, including the calculus behind the least-square fit for scatter plots. A brief introduction to inferential statistics and its relationship to descriptive statistics is also given, including a discussion of causation in statistical analyses.

12 Probability Probability theory represents an important area of mathematics in the life sciences and it also forms the foundation for the study of inferential statistics. Basic principles of counting and their application are introduced first, and these are then used to motivate an intuitive definition of probability. This definition is then generalized to the axiomatic definition of probability in an accessible way that highlights the meanings of the axioms in a biological context. Conditional probability is then introduced with important applications to disease testing, handedness, color blindness, genetic disorders, and gender. The final two sections introduce discrete and continuous random variables and illustrate how these arise naturally in many biological contexts, from disease outbreaks to DNA supercoiling. They also demonstrate how the concepts of differentiation and integration are central components of probability theory.

13 Inferential Statistics The final chapter addresses the important issue of how one takes information from a data set and uses it to make inferences about the population from which it was collected. We do not provide an exhaustive treatment of inferential statistics, but instead present some of its core ideas and how they relate to calculus. Sampling distributions are explained, along with confidence intervals and the logic behind hypothesis testing. The chapter concludes with a simplified treatment of the central ideas behind contingency table analysis.

Student Resources

Enhanced WebAssign® ENHANCED WebAssign

Printed Access Code ISBN: 978-1-285-85826-5

Instant Access Code ISBN: 978-1-285-85825-8

Enhanced WebAssign is designed to allow you to do your homework online. This proven and reliable system uses content found in this text, then enhances it to help you learn calculus more effectively. Automatically graded homework allows you to focus on your learning and get interactive study assistance outside of class. Enhanced WebAssign for *Biocalculus: Calculus, Probability, and Statistics for the Life Sciences* contains the Cengage YouBook, an interactive ebook that contains animated figures, video clips, highlighting and note-taking features, and more!

CengageBrain.com

To access additional course materials, please visit www.cengagebrain.com. At the CengageBrain.com home page, search for the ISBN of your title (from the back cover of your book) using the search box at the top of the page. This will take you to the product page where these resources can be found.

Stewart Website

www.stewartcalculus.com

This site includes additional biological background for selected examples, exercises, and projects, including animations, further references, and downloadable data files. In addition, the site includes the following:

- Algebra Review
- Additional Topics
- Drill exercises
- Challenge Problems
- Web Links
- History of Mathematics
- Tools for Enriching Calculus (TEC)

Student Solutions Manual

ISBN: 978-1-305-11406-7

Provides completely worked-out solutions to all odd-numbered exercises in the text, giving you a chance to check your answers and ensure you took the correct steps to arrive at an answer.

A Companion to Calculus

By Dennis Ebersole, Doris Schattschneider, Alicia Sevilla, and Kay Somers

ISBN 978-0-495-01124-8

Written to improve algebra and problem-solving skills of students taking a calculus course, every chapter in this companion is keyed to a calculus topic, providing conceptual background and specific algebra techniques needed to understand and solve calculus problems related to that topic. It is designed for calculus courses that integrate the review of precalculus concepts or for individual use. Order a copy of the text or access the eBook online at www.cengagebrain.com by searching the ISBN.

Linear Algebra for Calculus

by Konrad J. Heuvers, William P. Francis, John H. Kuisti,
Deborah F. Lockhart, Daniel S. Moak, and Gene M. Ortner
ISBN 978-0-534-25248-9

This comprehensive book, designed to supplement a calculus course, provides an introduction to and review of the basic ideas of linear algebra. Order a copy of the text or access the eBook online at www.cengagebrain.com by searching the ISBN.

Instructor Resources

Enhanced WebAssign® ENHANCED WebAssign

Printed Access Code ISBN: 978-1-285-85826-5

Instant Access Code ISBN: 978-1-285-85825-8

Exclusively from Cengage Learning, Enhanced WebAssign offers an extensive online program for *Biocalculus: Calculus, Probability, and Statistics for the Life Sciences* to encourage the practice that is so critical for concept mastery. The meticulously crafted pedagogy and exercises in our proven texts become even more effective in Enhanced WebAssign, supplemented by multimedia tutorial support and immediate feedback as students complete their assignments. Key features include:

- Thousands of homework problems that match your textbook's end-of-section exercises
- Opportunities for students to review prerequisite skills and content both at the start of the course and at the beginning of each section
- *Read It* eBook pages, *Watch It* videos, *Master It* tutorials, and *Chat About It* links
- A customizable Cengage Learning *YouBook* with highlighting, note-taking, and search features, as well as links to multimedia resources
- *Personal Study Plans* (based on diagnostic quizzing) that identify chapter topics that students will need to master
- A WebAssign *Answer Evaluator* that recognizes and accepts equivalent mathematical responses in the same way an instructor grades
- A *Show My Work* feature that gives instructors the option of seeing students' detailed solutions
- Lecture videos and more!

Cengage Customizable YouBook

YouBook is an eBook that is both interactive and customizable! Containing all the content from *Biocalculus: Calculus, Probability, and Statistics for the Life Sciences*, *YouBook* features a text edit tool that allows instructors to modify the textbook narrative as needed. With *YouBook*, instructors can quickly reorder entire sections and chapters or hide any content they don't teach to create an eBook that perfectly matches their syllabus. Instructors can further customize the text by adding instructor-created or YouTube video links. Additional media assets include animated figures, video clips, highlighting and note-taking features, and more! *YouBook* is available within Enhanced WebAssign.

Complete Solutions Manual

ISBN: 978-1-305-11407-4

Includes worked-out solutions to all exercises and projects in the text.

Instructor Companion Website (login.cengage.com)

This comprehensive instructor website contains all art from the text in both jpeg and PowerPoint formats.

Stewart Website

www.stewartcalculus.com

This comprehensive instructor website contains additional material to complement the text, marked by the logo **BB**. This material includes additional Biological Background for selected examples, exercises, and projects, including animations, further references, and downloadable data files. In addition, this site includes the following:

- Algebra Review
- Additional Topics
- Drill exercises
- Challenge Problems
- Web Links
- History of Mathematics
- Tools for Enriching Calculus (TEC)

Acknowledgments

We are grateful to the following reviewers and class testers for sharing their knowledge and judgment with us. We have learned something from each of them.

Reviewers

Anthony Barcellos, <i>American River College</i>	Eli Goldwyn, <i>University of California–Davis</i>
Frank Bauerle, <i>University of California–Santa Cruz</i>	Richard Gomulkiewicz, <i>Washington State University</i>
Barbara Bendl, <i>University of the Sciences in Philadelphia</i>	Genady Grabarnik, <i>St. John’s University</i>
Adam Bowers, <i>University of California–San Diego</i>	Mark Harbison, <i>Sacramento City College</i>
Richard Brown, <i>Johns Hopkins University</i>	Jane Heffernan, <i>York University</i>
Hannah Callender, <i>University of Portland</i>	Sophia Jang, <i>Texas Tech University</i>
Youn-Sha Chan, <i>University of Houston–Downtown</i>	Yang Kuang, <i>Arizona State University</i>
Alberto Corso, <i>University of Kentucky</i>	Emile LeBlanc, <i>University of Toronto</i>
Robert Crawford, <i>Sacramento City College</i>	Glenn Ledder, <i>University of Nebraska–Lincoln</i>
Dwight Duffus, <i>Emory University</i>	Alun Lloyd, <i>North Carolina State University</i>
Paula Federico, <i>Capital University</i>	Melissa Macasieb, <i>University of Maryland, College Park</i>
Guillermo Goldsztein, <i>Georgia Institute of Technology</i>	Edward Migliore, <i>University of California–Santa Cruz</i>
	Laura Miller, <i>University of North Carolina at Chapel Hill</i>

Val Mohanakumar, *Hillsborough
Community College–Dale Mabry*
Douglas Norton, *Villanova University*
Michael Price, *University of Oregon*
Suzanne Robertson, *Virginia
Commonwealth University*
Ayse Sahin, *DePaul University*
Asok Sen, *Indiana University–Purdue
University*
Ellis Shamash, *Loyola Marymount
University*
Patrick Shipman, *Colorado State
University*

Jeff Suzuki, *Brooklyn College*
Nicoleta Tarfulea, *Purdue University
Calumet*
Juan Tolosa, *Richard Stockton College
of New Jersey*
Gerda de Vries, *University of Alberta*
Lindi Wahl, *Western University*
Saleem Watson, *California State
University–Long Beach*
George Yates, *Youngstown State
University*

Class Testers

Ayse Sahin and her students, *DePaul University*, 2012–2013 academic year
Ilie Ugarcovici and his students, *DePaul University*, 2013–2014 academic year
Michael Price and his students, *University of Oregon*, 2013–2014 academic year

In addition we would like to thank Alan Ableson, Daniel Ashlock, Kathy Davis, David Earn, Brian Gilbert, Lisa Hicks, Bob Montgomerie, Bill Nelson, Sarah Otto, Mary Pugh, Peter Taylor, Ron Wald, and Gail Wolkowicz for their advice and suggestions. We are particularly indebted to Jane Heffernan, for the contributions she made in Chapters 5 and 6 on measles pathogenesis, and to Lindi Wahl, for her careful editing of Chapters 11–13. Special thanks go to Alan Hastings and Saleem Watson for the extensive advice they gave us at the beginning of this writing project.

We also thank Kathi Townes, Stephanie Kuhns, Kira Abdallah, and Kristina Elliott at TECHarts for their production services; Josh Babbín for exercise solutions, Andrew Bulman-Fleming for solutions art, Lauri Semarne for solutions accuracy check; Lisa Henry for the cover image and text and cover design; and the following Cengage Learning staff: product manager Neha Taleja, senior content developer Stacy Green, associate content developer Samantha Lugtu, media developer Lynh Pham, product assistant Stephanie Kreuz, marketing manager Ryan Ahern, senior product development specialist Katherine Greig, content project manager Cheryll Linthicum, art director Vernon Boes, and manufacturing planner Rebecca Cross. They have all done an outstanding job.

JAMES STEWART
TROY DAY

To the Student

Reading a calculus textbook is different from reading a newspaper or a novel, or even a physics book. Don't be discouraged if you have to read a passage more than once in order to understand it. You should have pencil and paper and calculator at hand to sketch a diagram or make a calculation.

Some students start by trying their homework problems and read the text only if they get stuck on an exercise. We suggest that a far better plan is to read and understand a section of the text before attempting the exercises. In particular, you should look at the definitions to see the exact meanings of the terms. And before you read each example, we suggest that you cover up the solution and try solving the problem yourself. You'll get a lot more from looking at the solution if you do so.

Part of the aim of this course is to train you to think logically. Learn to write the solutions of the exercises in a connected, step-by-step fashion with explanatory sentences—not just a string of disconnected equations or formulas.

The answers to the odd-numbered exercises appear at the back of the book. Some exercises ask for a verbal explanation or interpretation or description. In such cases there is no single correct way of expressing the answer, so don't worry that you haven't found the definitive answer. In addition, there are often several different forms in which to express a numerical or algebraic answer, so if your answer differs from ours, don't immediately assume you're wrong. For example, if the answer given in the back of the book is $\sqrt{2} - 1$ and you obtain $1/(1 + \sqrt{2})$, then you're right and rationalizing the denominator will show that the answers are equivalent.

The icon  indicates an exercise that definitely requires the use of either a graphing calculator or a computer with graphing software. (*Calculators, Computers, and Other*

Graphing Devices discusses the use of these graphing devices and some of the pitfalls that you may encounter.) But that doesn't mean that graphing devices can't be used to check your work on the other exercises as well. The symbol **CAS** is reserved for problems in which the full resources of a computer algebra system (like Derive, Maple, Mathematica, or the TI-89/92) are required.

You will also encounter the symbol , which warns you against committing an error. We have placed this symbol in the margin in situations where we have observed that a large proportion of students tend to make the same mistake.

Applications with additional Biology Background available on www.stewartcalculus.com are marked with the icon **BB** in the text.

Tools for Enriching Calculus, which is a companion to this text, is referred to by means of the symbol **TEC** and can be accessed in Enhanced WebAssign (selected Visuals and Modules are available at www.stewartcalculus.com). It directs you to modules in which you can explore aspects of calculus for which the computer is particularly useful.

We recommend that you keep this book for reference purposes after you finish the course. Because you will likely forget some of the specific details of calculus, the book will serve as a useful reminder when you need to use calculus in subsequent courses. And, because this book contains more material than can be covered in any one course, it can also serve as a valuable resource for a working biologist.

Calculus is an exciting subject, justly considered to be one of the greatest achievements of the human intellect. We hope you will discover that it is not only useful but also intrinsically beautiful.

JAMES STEWART

TROY DAY

Calculators, Computers, and Other Graphing Devices

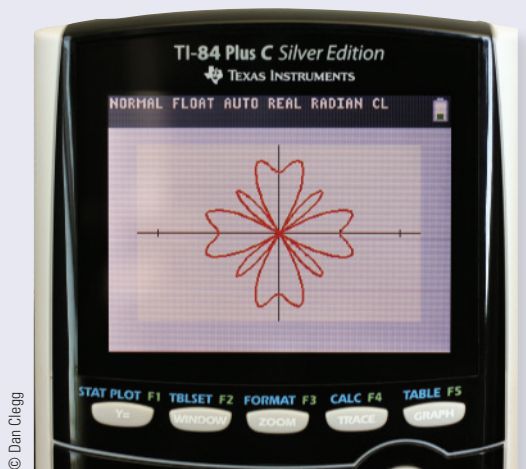

© Dan Clegg

Advances in technology continue to bring a wider variety of tools for doing mathematics. Handheld calculators are becoming more powerful, as are software programs and Internet resources. In addition, many mathematical applications have been released for smartphones and tablets such as the iPad.

Some exercises in this text are marked with a graphing icon , which indicates that the use of some technology is required. Often this means that we intend for a graphing device to be used in drawing the graph of a function or equation. You might also need technology to find the zeros of a graph or the points of intersection of two graphs. In some cases we will use a calculating device to solve an equation or evaluate a definite integral numerically. Many scientific and graphing calculators have these features built in, such as the Texas Instruments TI-84 or TI-Nspire CX. Similar calculators are made by Hewlett Packard, Casio, and Sharp.

You can also use computer software such as *Graphing Calculator* by Pacific Tech (www.pacifict.com) to perform many of these functions, as well as apps for phones and tablets, like Quick Graph (Colombiamug) or MathStudio (Pomegranate Apps). Similar functionality is available using a web interface at WolframAlpha.com.

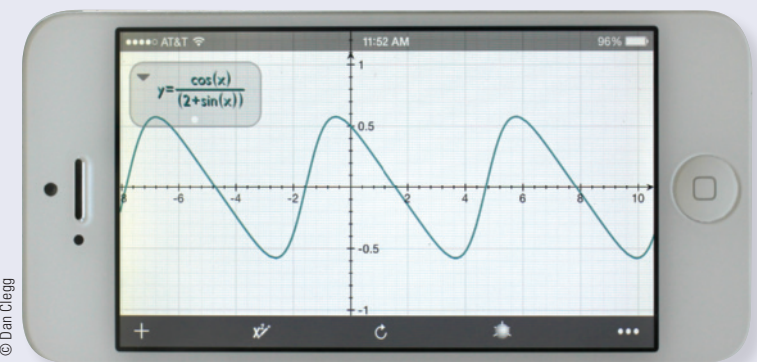

© Dan Clegg



© Dan Clegg

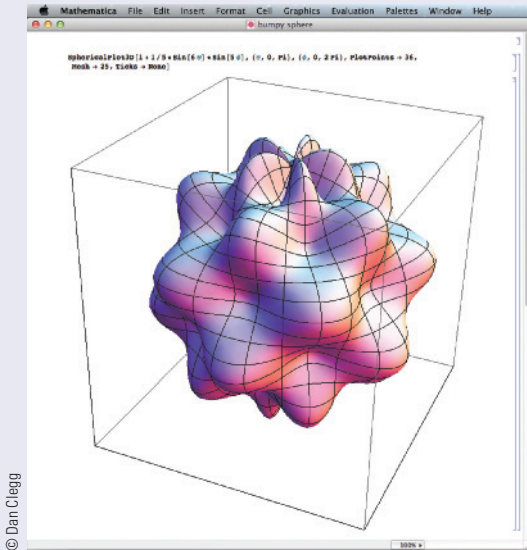

© Dan Clegg

In general, when we use the term “calculator” in this book, we mean the use of any of the resources we have mentioned.

The **CAS** icon is reserved for problems in which the full resources of a *computer algebra system* (CAS) are required. A CAS is capable of doing mathematics (like solving equations, computing derivatives or integrals) *symbolically* rather than just numerically.

Examples of well-established computer algebra systems are the computer software packages Maple and Mathematica. The WolframAlpha website uses the Mathematica engine to provide CAS functionality via the Web.

Many handheld graphing calculators have CAS capabilities, such as the TI-89 and TI-Nspire CX CAS from Texas Instruments. Some tablet and smartphone apps also provide these capabilities, such as the previously mentioned MathStudio.

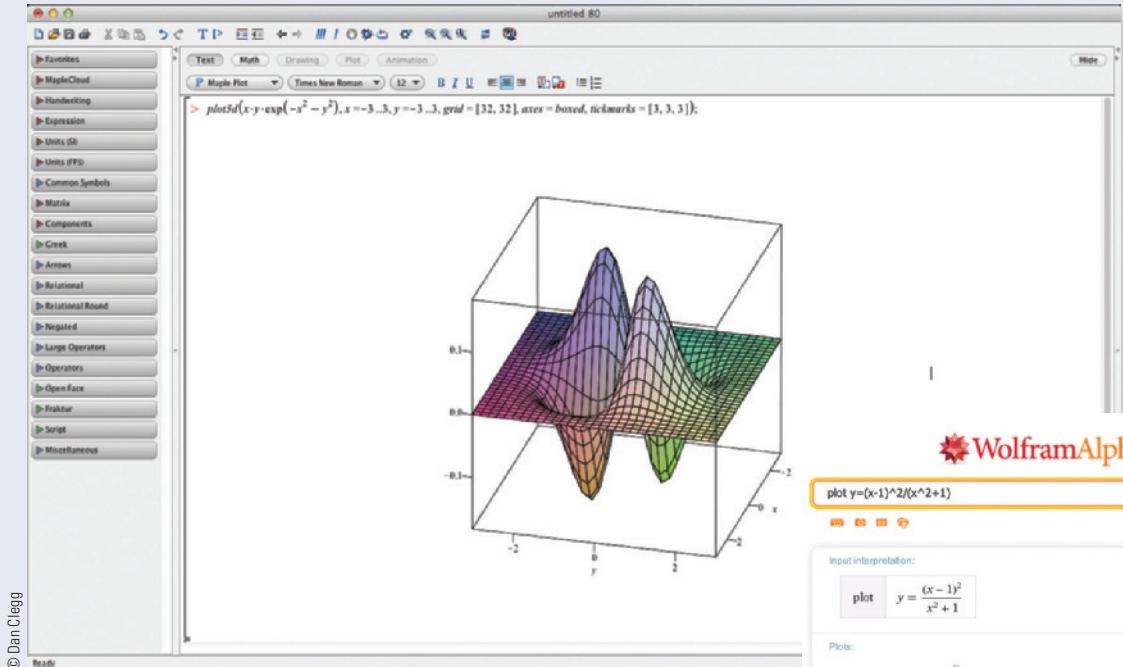

© Dan Clegg

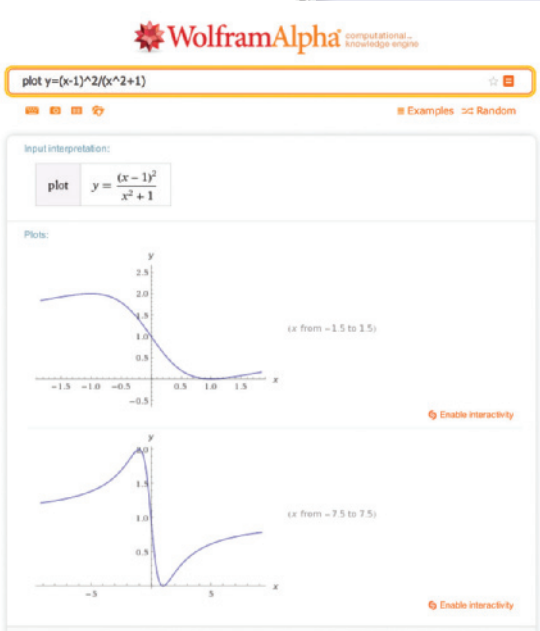

© Dan Clegg

Diagnostic Tests

Success in calculus depends to a large extent on knowledge of the mathematics that precedes calculus. The following tests are intended to diagnose weaknesses that you might have. After taking each test you can check your answers against the given answers and, if necessary, refresh your skills by referring to the review materials that are provided.

A Diagnostic Test: Algebra

1. Evaluate each expression without using a calculator.

- (a) $(-3)^4$ (b) -3^4 (c) 3^{-4}
(d) $\frac{5^{23}}{5^{21}}$ (e) $\left(\frac{2}{3}\right)^{-2}$ (f) $16^{-3/4}$

2. Simplify each expression. Write your answer without negative exponents.

- (a) $\sqrt{200} - \sqrt{32}$
(b) $(3a^3b^3)(4ab^2)^2$
(c) $\left(\frac{3x^{3/2}y^3}{x^2y^{-1/2}}\right)^{-2}$

3. Expand and simplify.

- (a) $3(x + 6) + 4(2x - 5)$ (b) $(x + 3)(4x - 5)$
(c) $(\sqrt{a} + \sqrt{b})(\sqrt{a} - \sqrt{b})$ (d) $(2x + 3)^2$
(e) $(x + 2)^3$

4. Factor each expression.

- (a) $4x^2 - 25$ (b) $2x^2 + 5x - 12$
(c) $x^3 - 3x^2 - 4x + 12$ (d) $x^4 + 27x$
(e) $3x^{3/2} - 9x^{1/2} + 6x^{-1/2}$ (f) $x^3y - 4xy$

5. Simplify the rational expression.

- (a) $\frac{x^2 + 3x + 2}{x^2 - x - 2}$ (b) $\frac{2x^2 - x - 1}{x^2 - 9} \cdot \frac{x + 3}{2x + 1}$
(c) $\frac{x^2}{x^2 - 4} - \frac{x + 1}{x + 2}$ (d) $\frac{\frac{y}{x} - \frac{x}{y}}{\frac{1}{y} - \frac{1}{x}}$

6. Rationalize the expression and simplify.

(a) $\frac{\sqrt{10}}{\sqrt{5} - 2}$

(b) $\frac{\sqrt{4+h} - 2}{h}$

7. Rewrite by completing the square.

(a) $x^2 + x + 1$

(b) $2x^2 - 12x + 11$

8. Solve the equation. (Find only the real solutions.)

(a) $x + 5 = 14 - \frac{1}{2}x$

(b) $\frac{2x}{x+1} = \frac{2x-1}{x}$

(c) $x^2 - x - 12 = 0$

(d) $2x^2 + 4x + 1 = 0$

(e) $x^4 - 3x^2 + 2 = 0$

(f) $3|x - 4| = 10$

(g) $2x(4-x)^{-1/2} - 3\sqrt{4-x} = 0$

9. Solve each inequality. Write your answer using interval notation.

(a) $-4 < 5 - 3x \leq 17$

(b) $x^2 < 2x + 8$

(c) $x(x-1)(x+2) > 0$

(d) $|x - 4| < 3$

(e) $\frac{2x-3}{x+1} \leq 1$

10. State whether each equation is true or false.

(a) $(p+q)^2 = p^2 + q^2$

(b) $\sqrt{ab} = \sqrt{a}\sqrt{b}$

(c) $\sqrt{a^2 + b^2} = a + b$

(d) $\frac{1+TC}{C} = 1 + T$

(e) $\frac{1}{x-y} = \frac{1}{x} - \frac{1}{y}$

(f) $\frac{1/x}{a/x - b/x} = \frac{1}{a-b}$

ANSWERS TO DIAGNOSTIC TEST A: ALGEBRA

- | | | | | | |
|----------------------------|------------------------|----------------------|--|--------------------------------|---------------------------------|
| 1. (a) 81 | (b) -81 | (c) $\frac{1}{81}$ | 6. (a) $5\sqrt{2} + 2\sqrt{10}$ | (b) $\frac{1}{\sqrt{4+h} + 2}$ | |
| (d) 25 | (e) $\frac{9}{4}$ | (f) $\frac{1}{8}$ | 7. (a) $(x + \frac{1}{2})^2 + \frac{3}{4}$ | (b) $2(x-3)^2 - 7$ | |
| 2. (a) $6\sqrt{2}$ | (b) $48a^5b^7$ | (c) $\frac{x}{9y^7}$ | 8. (a) 6 | (b) 1 | (c) -3, 4 |
| 3. (a) $11x - 2$ | (b) $4x^2 + 7x - 15$ | | (d) $-1 \pm \frac{1}{2}\sqrt{2}$ | (e) $\pm 1, \pm\sqrt{2}$ | (f) $\frac{2}{3}, \frac{22}{3}$ |
| (c) $a - b$ | (d) $4x^2 + 12x + 9$ | | (g) $\frac{12}{5}$ | | |
| (e) $x^3 + 6x^2 + 12x + 8$ | | | 9. (a) $[-4, 3)$ | (b) $(-2, 4)$ | |
| 4. (a) $(2x-5)(2x+5)$ | (b) $(2x-3)(x+4)$ | | (c) $(-2, 0) \cup (1, \infty)$ | (d) $(1, 7)$ | |
| (c) $(x-3)(x-2)(x+2)$ | (d) $x(x+3)(x^2-3x+9)$ | | (e) $(-1, 4]$ | | |
| (e) $3x^{-1/2}(x-1)(x-2)$ | (f) $xy(x-2)(x+2)$ | | | | |
| 5. (a) $\frac{x+2}{x-2}$ | (b) $\frac{x-1}{x-3}$ | | 10. (a) False | (b) True | (c) False |
| (c) $\frac{1}{x-2}$ | (d) $-(x+y)$ | | (d) False | (e) False | (f) True |

If you had difficulty with these problems, you may wish to consult the Review of Algebra on the website www.stewartcalculus.com.

B Diagnostic Test: Analytic Geometry

- Find an equation for the line that passes through the point $(2, -5)$ and
 - has slope -3
 - is parallel to the x -axis
 - is parallel to the y -axis
 - is parallel to the line $2x - 4y = 3$
- Find an equation for the circle that has center $(-1, 4)$ and passes through the point $(3, -2)$.
- Find the center and radius of the circle with equation $x^2 + y^2 - 6x + 10y + 9 = 0$.
- Let $A(-7, 4)$ and $B(5, -12)$ be points in the plane.
 - Find the slope of the line that contains A and B .
 - Find an equation of the line that passes through A and B . What are the intercepts?
 - Find the midpoint of the segment AB .
 - Find the length of the segment AB .
 - Find an equation of the perpendicular bisector of AB .
 - Find an equation of the circle for which AB is a diameter.
- Sketch the region in the xy -plane defined by the equation or inequalities.
 - $-1 \leq y \leq 3$
 - $|x| < 4$ and $|y| < 2$
 - $y < 1 - \frac{1}{2}x$
 - $y \geq x^2 - 1$
 - $x^2 + y^2 < 4$
 - $9x^2 + 16y^2 = 144$

ANSWERS TO DIAGNOSTIC TEST B: ANALYTIC GEOMETRY

- (a) $y = -3x + 1$ (b) $y = -5$
(c) $x = 2$ (d) $y = \frac{1}{2}x - 6$
- $(x + 1)^2 + (y - 4)^2 = 52$
- Center $(3, -5)$, radius 5
- (a) $-\frac{4}{3}$
(b) $4x + 3y + 16 = 0$; x -intercept -4 , y -intercept $-\frac{16}{3}$
(c) $(-1, -4)$
(d) 20
(e) $3x - 4y = 13$
(f) $(x + 1)^2 + (y + 4)^2 = 100$

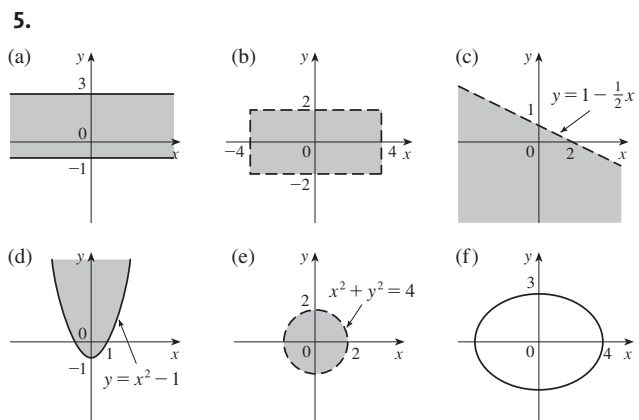

If you had difficulty with these problems, you may wish to consult the review of analytic geometry in Appendix B.

C Diagnostic Test: Functions

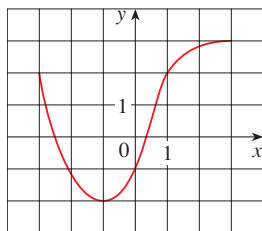
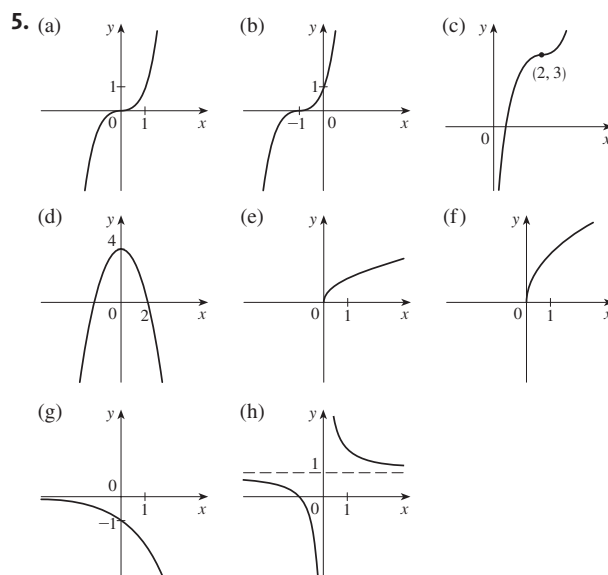

FIGURE FOR PROBLEM 1

- The graph of a function f is given at the left.
 - State the value of $f(-1)$.
 - Estimate the value of $f(2)$.
 - For what values of x is $f(x) = 2$?
 - Estimate the values of x such that $f(x) = 0$.
 - State the domain and range of f .
- If $f(x) = x^3$, evaluate the difference quotient $\frac{f(2+h) - f(2)}{h}$ and simplify your answer.
- Find the domain of the function.
 - $f(x) = \frac{2x + 1}{x^2 + x - 2}$
 - $g(x) = \frac{\sqrt[3]{x}}{x^2 + 1}$
 - $h(x) = \sqrt{4 - x} + \sqrt{x^2 - 1}$
- How are graphs of the functions obtained from the graph of f ?
 - $y = -f(x)$
 - $y = 2f(x) - 1$
 - $y = f(x - 3) + 2$
- Without using a calculator, make a rough sketch of the graph.
 - $y = x^3$
 - $y = (x + 1)^3$
 - $y = (x - 2)^3 + 3$
 - $y = 4 - x^2$
 - $y = \sqrt{x}$
 - $y = 2\sqrt{x}$
 - $y = -2^x$
 - $y = 1 + x^{-1}$
- Let $f(x) = \begin{cases} 1 - x^2 & \text{if } x \leq 0 \\ 2x + 1 & \text{if } x > 0 \end{cases}$
 - Evaluate $f(-2)$ and $f(1)$.
 - Sketch the graph of f .
- If $f(x) = x^2 + 2x - 1$ and $g(x) = 2x - 3$, find each of the following functions.
 - $f \circ g$
 - $g \circ f$
 - $g \circ g \circ g$

ANSWERS TO DIAGNOSTIC TEST C: FUNCTIONS

- (a) -2
 - (b) 2.8
 - (c) $-3, 1$
 - (d) $-2.5, 0.3$
 - (e) $[-3, 3], [-2, 3]$
- $12 + 6h + h^2$
- (a) $(-\infty, -2) \cup (-2, 1) \cup (1, \infty)$
 - (b) $(-\infty, \infty)$
 - (c) $(-\infty, -1] \cup [1, 4]$
- (a) Reflect about the x -axis
 - (b) Stretch vertically by a factor of 2, then shift 1 unit downward
 - (c) Shift 3 units to the right and 2 units upward



6. (a) $-3, 3$

(b)

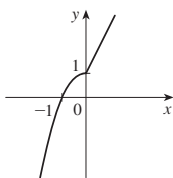

7. (a) $(f \circ g)(x) = 4x^2 - 8x + 2$

(b) $(g \circ f)(x) = 2x^2 + 4x - 5$

(c) $(g \circ g \circ g)(x) = 8x - 21$

If you had difficulty with these problems, you should look at sections 1.1–1.3 of this book.

D Diagnostic Test: Trigonometry

1. Convert from degrees to radians.

(a) 300° (b) -18°

2. Convert from radians to degrees.

(a) $5\pi/6$ (b) 2

3. Find the length of an arc of a circle with radius 12 cm if the arc subtends a central angle of 30° .

4. Find the exact values.

(a) $\tan(\pi/3)$ (b) $\sin(7\pi/6)$ (c) $\sec(5\pi/3)$

5. Express the lengths a and b in the figure in terms of θ .6. If $\sin x = \frac{1}{3}$ and $\sec y = \frac{5}{4}$, where x and y lie between 0 and $\pi/2$, evaluate $\sin(x + y)$.

7. Prove the identities.

(a) $\tan \theta \sin \theta + \cos \theta = \sec \theta$ (b) $\frac{2 \tan x}{1 + \tan^2 x} = \sin 2x$

8. Find all values of x such that $\sin 2x = \sin x$ and $0 \leq x \leq 2\pi$.9. Sketch the graph of the function $y = 1 + \sin 2x$ without using a calculator.

FIGURE FOR PROBLEM 5

ANSWERS TO DIAGNOSTIC TEST D: TRIGONOMETRY

1. (a) $5\pi/3$

(b) $-\pi/10$

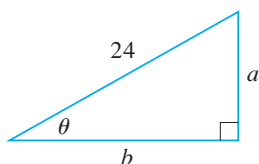
2. (a) 150°

(b) $360^\circ/\pi \approx 114.6^\circ$

3. 2π cm

4. (a) $\sqrt{3}$

(b) $-\frac{1}{2}$

(c) 2

5. (a) $24 \sin \theta$

(b) $24 \cos \theta$

6. $\frac{1}{15}(4 + 6\sqrt{2})$

8. $0, \pi/3, \pi, 5\pi/3, 2\pi$

9.

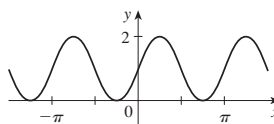

If you had difficulty with these problems, you should look at Appendix C of this book.

Prologue: Mathematics and Biology

Galileo was keenly aware of the role of mathematics in the study of nature. In 1610 he famously wrote:

Philosophy [Nature] is written in that great book which ever lies before our eye—I mean the universe—but we cannot understand it if we do not first learn the language and grasp the symbols in which it is written. The book is written in the language of mathematics and the symbols are triangles, circles, and other geometrical figures, without whose help it is impossible to comprehend a single word of it; without which one wanders in vain through a dark labyrinth.¹

Indeed, in the seventeenth and later centuries Newton and other scientists employed mathematics in trying to explain physical phenomena. First physics and astronomy, and later chemistry, were investigated with the methods of mathematics. Most of the applications of mathematics to biology, however, occurred much later.

A connection between mathematics and biology that was noticed at an early stage was phyllotaxy, which literally means leaf arrangement. For some trees, such as the elm, the leaves occur alternately, on opposite sides of a branch, and we refer to $\frac{1}{2}$ phyllotaxis because the next leaf is half of a complete turn (rotation) beyond the first one. For beech trees each leaf is a third of a turn beyond the preceding one and we have $\frac{1}{3}$ phyllotaxis. Oak trees exhibit $\frac{2}{5}$ phyllotaxis, poplar trees $\frac{3}{8}$ phyllotaxis, and willow trees $\frac{5}{13}$ phyllotaxis. These fractions

$$\frac{1}{2} \quad \frac{1}{3} \quad \frac{2}{5} \quad \frac{3}{8} \quad \frac{5}{13} \quad \dots$$

are related to the Fibonacci numbers

$$1 \quad 1 \quad 2 \quad 3 \quad 5 \quad 8 \quad 13 \quad 21 \quad 34 \quad \dots$$

which we will study in Section 1.6. Each of the Fibonacci numbers is the sum of the two preceding numbers. Notice that each of the phyllotaxis fractions is a ratio of Fibonacci numbers spaced two apart. It has been suggested that the adaptive advantage of this arrangement of leaves comes from maximizing exposure to sunlight and rainfall.

The Fibonacci numbers also arise in other botanical examples of phyllotaxis: the spiral patterns of the florets of a sunflower, the scales of a fir cone, and the hexagonal cells of a pineapple. Shown are three types of spirals on a pineapple: 5 spirals sloping up gradually to the right, 8 spirals sloping up to the left, and 13 sloping up steeply.

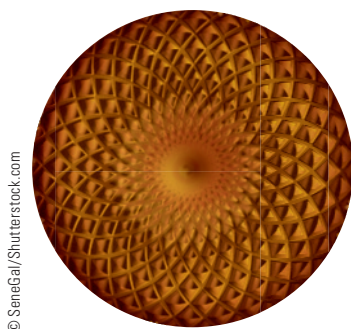

© Senegal/Shutterstock.com



5 parallel spirals



8 parallel spirals



13 parallel spirals

1. Galileo Galilei, *Le Opere di Galileo Galilei*, Edizione Nazionale, 20 vols., ed. Antonio Favaro (Florence: G. Barbera, 1890–1909; reprinted 1929–39, 1964–66), vol. 4, p. 171.

Another early application of mathematics to biology was the study of the spread of smallpox by the Swiss mathematician Daniel Bernoulli in the 1760s. Bernoulli formulated a mathematical model of an epidemic of an infectious disease in the form of a differential equation. (Such equations will be studied in Chapter 7.) In particular, Bernoulli showed that, under the assumptions of his model, life expectancy would increase by more than three years if the entire population were inoculated at birth for smallpox. His work was the start of the field of mathematical epidemiology, which we will explore extensively in this book.

Aside from a few such instances, however, mathematical biology was slow to develop, probably because of the complexity of biological structures and processes. In the last few decades, however, the field has burgeoned. In fact, Ian Stewart has predicted that “Biology will be the great mathematical frontier of the twenty-first century.”²

Already the scope of mathematical applications to biology is enormous, having led to important insights that have revolutionized our understanding of biological processes and spawned new fields of study. These successes have reached the highest levels of scientific recognition, resulting in Nobel Prizes to Ronald Ross in 1902 for his work on malaria transmission dynamics, to Alan Lloyd Hodgkin and Andrew Fielding Huxley in 1963 for their work on the transmission of nerve impulses, and to Alan Cormack and Godfrey Hounsfield in 1979 for the development of the methodology behind the now-common medical procedure of CAT scans. You will learn some of the mathematics behind each of these fundamental discoveries throughout this book.

Perhaps even more telling of the importance of mathematics to modern biology is the breadth of biological areas to which mathematics contributes. For example, mathematical analyses are central to our understanding of disease, from the function of immune molecules like natural killer cells and the occurrence of autoimmune diseases like lupus, to the spread of drug resistance. Likewise, modern medical treatments and techniques, from drug pharmacokinetics and dialysis, to the lung preoxygenation and hemodilution techniques used for surgery, have all been developed through the use of mathematical models.

The reach of mathematics in modern biology extends far beyond medicine, however, and is fundamental to virtually all areas of biology. Mathematical models and analyses are now routinely used in the study of physiology, from the growth and morphological structure of organisms, to photosynthesis, to the emergence of ordered patterns during cell division, to the dynamics of cell cycles and genome expression. Mathematics is used to understand organism movement, from humans to jellyfish, and to understand population and ecological processes, as well as the roles of habitat destruction and harvesting in the conservation of endangered species.

All of these applications are just a few of those explored in this book (a complete list can be found at the back of the book). But this book is just the beginning of the story. Modern biology and mathematics are now connected by a two-way street, with biological phenomena providing the impetus for advanced mathematical and computational analyses that go well beyond introductory calculus, probability, and statistics. High-tech research companies like Microsoft now have computational biology departments that examine the parallels between biological systems and computation. And these, in turn, are providing critical insight into a broad array of questions. From the dramatic failure and subsequent discontinuation of the breast cancer drug bevacizumab (Avastin) in 2011,³ to the very nature of life itself, mathematics and biology are now moving for-

2. I. Stewart, *The Mathematics of Life* (New York: Basic Books, 2011).

3. N. Savage, “Computing Cancer,” *Nature* (2012) 491: S62.

ward hand in hand. Techniques in advanced geometry are being developed to quantify similarities between different biological patterns, from electrical impulses in the neural cortex, to peptide sequences and patterns of protein folding. And these analyses have very close mathematical connections to other kinds of pattern matching as well, including those used by Web search engines like Google. Likewise, seemingly abstract topics from advanced algebra are being used in the statistical analysis of the reams of DNA sequence data that are now available and such biological questions are, in turn, reinvigorating these abstract areas of mathematics.⁴

This textbook provides the first steps into this exciting and fast-moving area that combines mathematics with biology. As motivation for our studies, we conclude this prologue with a brief description of some of the areas of application that will be covered.

Calculus and Biology

Living organisms change: they move, they grow, they reproduce. Calculus can be regarded as the mathematics of change. So it is natural that calculus plays a major role in mathematical biology. The following highlighted examples of applications are some of the recurring themes throughout the book. As we learn more calculus, we repeatedly return to these topics with increasing depth.

© George Burba / Shutterstock.com



■ Species Richness

It seems reasonable that the larger the area of a region, the larger will be the number of species that inhabit that region. To make scientific progress, however, we need to describe this relationship more precisely. Can we describe such species–area relationships mathematically, and can we use mathematics to better understand the processes that give rise to these patterns?

In Examples 1.2.6 and 1.5.14 we show that the species–area relation for bats in Mexican caves is well modeled using functions called power functions. Later, in Exercise 3.3.48, we show the same is true for tree species in Malaysian forests and then use the model to determine the rate at which the number of species grows as the area increases. When we study differential equations in Chapter 7, we show how assumptions about rates of increase of species lead naturally to such power-function models. In Example 4.2.5 we also see, however, that for very large areas the power-function model is no longer appropriate.

© Sebastian Kaultzki / Shutterstock.com



■ Vectorcardiography

Heartbeat patterns can be used to diagnose a variety of different medical conditions. These patterns are usually recorded by measuring the electrical potential on the surface of the body using several (often 12) wires, or “leads.” How can we use the measurements from these leads to diagnose heart problems?

In Section 1.1 and Example 4.1.4 we introduce the idea of using functions to describe heartbeats. We then consider, in Exercises 4.1.5–6, how the shapes of their graphs are diagnostic of different heart conditions. In Chapter 8 we introduce vectors and show how the direction of the voltage vector created by a heartbeat can be measured with ECG leads using the dot product (Example 8.3.7) and how this can be used to diagnose spe-

4. L. Pachter and B. Sturmfels, *Algebraic Statistics for Computational Biology* (Cambridge: Cambridge University Press, 2005).

cific heart conditions (Exercises 8.2.39, 8.3.40, and 8.7.7). We also show how the techniques of matrix algebra can be used to model the change in the heartbeat voltage vector (Exercises 8.5.16, 8.6.30, and 8.6.35).



© monticello / Shutterstock.com

■ Drug and Alcohol Metabolism

Biomedical scientists study the chemical and physiological changes that result from the metabolism of drugs and alcohol after consumption. How does the level of alcohol in the blood vary over time after the consumption of a drink, and can we use mathematics to better understand the processes that give rise to these patterns?

In Exercise 1.1.26 we present some data that we use to sketch the graph of the blood alcohol concentration (BAC) function, illustrating the two stages of the reaction in the human body: absorption and metabolism. In Exercises 1.4.34 and 1.5.69 we model the second stage with a decaying exponential function to determine when the BAC will be less than the legal limit. In Chapter 3 we model the entire two-stage process with a surge function and use it to estimate the rate of increase of the BAC in the first stage and the rate of decrease in the second stage (Exercise 3.5.59). Later we find the maximum value of the BAC (Example 4.1.7), the limiting value (Example 4.3.9), and the average value (Exercise 6.2.16).



© CreativeNature.nl / Shutterstock.com

■ Population Dynamics

One of the central goals of population biology and ecology is to describe the abundance and distribution of organisms and species over time and space. Can we use mathematical models to describe the processes that alter these abundances, and can these models then be used to predict population sizes?

In Section 1.1 we begin by using different representations of functions to describe the human population. Section 1.4 then illustrates how exponential functions can be used to model population change, from humans to malaria. Section 1.6 introduces recursion equations, which are fundamental tools used to study population dynamics. Several examples and exercises in Chapters 3 and 4 use calculus to show how derivatives of functions can tell us important information about the rate of growth of populations, while Chapters 5 and 6 illustrate how integration can be used to quantify the size of populations. Chapters 7, 8 and 10 then use differential equations and techniques from matrix algebra to model populations and show that populations can even exhibit chaotic behavior (see the project on page 430).

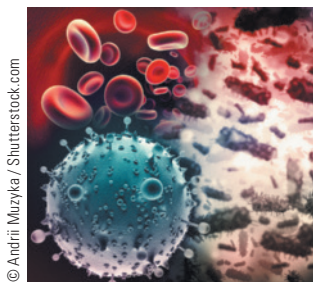

© Anrii Muzyka / Shutterstock.com

■ Antigenic Cartography and Vaccine Design

Cartography is the study of mapmaking. “Antigenic cartography” involves making maps of the antigenic properties of viruses. This allows us to better understand the changes that occur from year to year in viruses such as influenza. How can we describe these changes? Why is it that flu vaccines need to be updated periodically because of vaccine escape, and can we use mathematics to understand this process and to design new vaccines?

In Exercises 4.1.7 and 4.1.8 we use calculus to explore the epidemiological consequences of the antigenic change that occurs during an influenza pandemic. In the project on page 479 we model these processes using differential equations and determine the vaccine coverage needed to prevent an outbreak. Chapter 8 introduces the ideas of vectors and the geometry of higher-dimensional space and uses them in antigenic cartography (Exam-

ples 8.1.3, 8.1.6, and 8.1.8 and Exercise 8.1.39) and in vaccine design (Exercise 8.1.38). Vectors are then used to quantify antigenic evolution in Example 8.2.1 and Exercises 8.2.46, 8.3.37, 8.5.17, 8.6.31, and differential equations are used in the project on page 514 to understand vaccine escape.



© Maridav / Shutterstock.com

■ Biomechanics of Human Movement

When you walk, the horizontal force that the ground exerts on you is a function of time. Understanding human movement, and the energetic differences between walking, running, and other animal gaits, like galloping, requires an understanding of these forces. Can we quantify these processes using mathematical models?

The description of these forces when you are walking is investigated in Exercises 1.1.16 and 3.2.14. If you now start walking faster and faster and then begin to run, your gait changes. The metabolic power that you consume is a function of your speed and this is explored in Examples 1.1.10 and 3.2.7. In the project on page 40 we use trigonometric functions of time to model the vertical force that you exert on the ground with different gaits. In Chapter 8 we then introduce a three-dimensional coordinate system, enabling us to analyze the trajectory of the center of a human walking on a treadmill. Vectors are introduced in Section 8.2 and so we can then talk about the force vectors, such as those that sprinters exert on starting blocks (Example 8.2.6 and Exercise 8.2.38).

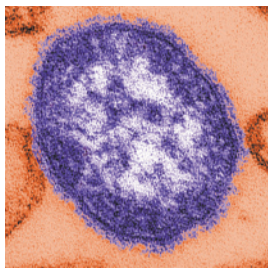

Scott Camazine / Alamy

■ Measles Pathogenesis

Infection with the measles virus results in symptoms and viral transmission in some patients and not in others. What causes these different outcomes, and can we predict when each is expected to occur?

The level of the measles virus in the bloodstream of a patient with no immunity peaks after about two weeks and can be modeled using a third-degree polynomial (Exercise 4.4.8). The area under this curve for the first 12 days turns out to be the total amount of infection needed for symptoms to develop (see the heading *Pathogenesis* on page 325 and Exercises 5.1.9 and 5.3.45). In the project on page 394 we consider patients with partial immunity, and by evaluating areas between curves we are able to decide which patients will be symptomatic and infectious (or noninfectious), as well as those who will be asymptomatic and noninfectious.



© leonello calvetti / Shutterstock.com

■ Blood Flow

The heart pumps blood through a series of interconnected vessels in your body. Several medical problems involve abnormal blood pressure and flow. Can we predict blood pressure and flow as a function of various physiological characteristics?

In Example 3.3.9 and Exercises 3.3.49 and 3.5.92 we use Poiseuille's law of laminar flow to calculate the rate at which the velocity of blood flow in arteries changes with respect to the distance from the center of the artery and with respect to time. In Exercise 6.3.10 we show how blood pressure depends on the radius of an artery. In the section *Cerebral Blood Flow* on page 390 we explain the Kety-Schmidt method, which is a diagnostic technique for measuring cerebral blood flow using inhaled nitrous oxide as a tracer. This method depends on knowing the area between two curves representing the concentration of nitrous oxide as blood enters the brain and the concentration as blood leaves the brain in the jugular vein. (See Example 6.1.4 and Exercises 6.1.21–22.)



© Vlada67 / Shutterstock.com

■ Conservation Biology

Human impacts arising from natural resource extraction and pollution are having devastating effects on many ecosystems. It is crucial that we be able to forecast these effects in order to better manage our impact on the environment. Mathematics is playing a central role in this endeavor.

Exercise 3.1.41 shows how derivatives can be used to study thermal pollution, while Exercises 3.5.91 and 3.8.43 use derivatives to determine the effect of habitat fragmentation on population dynamics. The project on page 239, as well as Example 4.4.5 and Exercises 4.4.21 and 4.5.21, use derivatives to explore the effect of harvesting on population sustainability. The project on page 298 then extends these ideas with an introduction to game theory. In Exercises 7.4.32–34 and Section 10.3 we use differential equations to model the effects of habitat destruction and pollution, while in Example 8.5.1 and Exercise 8.5.22 techniques from matrix algebra are used to model the conservation biology of right whales and spotted owls, respectively. The stability of coral reef ecosystems is explored using differential equations in Exercise 10.4.34.

Probability, Statistics, and Biology

The mathematical tools of probability and statistics (both of which rely on calculus) are also fundamental to many areas of modern biology. Many biological processes—like species extinctions, the inheritance of genetic diseases, and the likelihood of success of medical procedures—involve aspects of chance that can be understood only with the use of probability theory. Furthermore, the statistical analysis of data forms the basis of all of science, including biology, and the tools of statistics are rooted in calculus and probability theory. Although this book is not the place for a thorough treatment of statistics, you will be introduced to some of the central concepts of the subject in Chapters 11 and 13.



© Rena Schild / Shutterstock.com

Performance-enhancing Drugs

Erythropoietin (EPO) is a hormone that stimulates red blood cell production. Synthetic variants of EPO are sometimes used by athletes in an attempt to increase aerobic capacity during competition. How effective is EPO at increasing performance?

In Exercise 11.1.19 we summarize data for the performance of athletes both before and after they have been given EPO, using various summary statistics. In Exercises 11.3.7 and 11.3.18 we then explore these data graphically. After learning some probability theory in Chapter 12, we can then begin to analyze the effects of EPO more rigorously using statistical techniques. Examples 13.3.2, 13.3.3, and 13.3.6 illustrate how we can use these techniques to test the hypothesis that EPO alters athletic performance.

© Creations / Shutterstock.com



DNA Supercoiling

When DNA is packaged into chromosomes, it is often coiled and twisted to make it more compact. This is called supercoiling. Some of these coils are very dynamic, repeatedly forming and disappearing at different locations throughout the genome. What causes this process?

One hypothesis is that the coils form and disappear randomly over time, as a result of chance twisting and untwisting of the DNA. To explore whether this hypothesis provides a reasonable explanation, we need to determine the pattern of supercoiling that it would cause. In Chapter 12 we introduce the necessary ideas of probability theory to model this process. The project after Section 12.4 then uses these ideas to model the random twisting and untwisting of supercoils. You will see that the available supercoiling data match the model predictions remarkably well.

© klenoh / Shutterstock.com

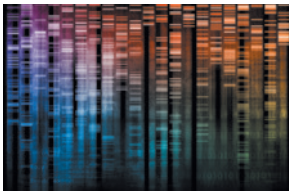

Huntington's Disease

Huntington's disease is a genetic disorder causing neurodegeneration and eventual death. Symptoms typically appear in a person's thirties and death occurs around 20 years after the onset of symptoms. What causes the variability in the age of onset, and how likely are you to inherit this disease if one of your parents has it?

In Exercise 11.1.14 we summarize data for the age of onset, and Exercises 11.2.15 and 11.2.29 explore the data graphically. Exercises 13.1.14 and 13.1.23 then use so-called “normal curves” to estimate the fraction of cases having different ages of onset. In Exercises 13.2.7 and 13.3.7 we use confidence intervals and hypothesis testing, respectively, to better understand the mean age of onset. Exercises 11.3.14 and 11.3.20 use statistical techniques to explore how the age of onset is related to different DNA sequences, and Examples 12.3.3 and 12.3.9 illustrate how probability theory can be used to predict the likelihood of a child inheriting the disease from its parents.

Case Studies in Mathematical Modeling

A **mathematical model** is a mathematical description (often by means of a function or an equation) of a real-world phenomenon, such as the size of a population, the speed of a falling object, the frequency of a particular gene, the concentration of an antibiotic in a patient, or the life expectancy of a person at birth. The purpose of the model is to understand the phenomenon and perhaps to make predictions about future behavior.

Figure 1 illustrates the process of mathematical modeling. Given a real-world problem, the first task is to formulate a mathematical model by identifying and naming the relevant quantities and making assumptions that simplify the phenomenon enough to make it mathematically tractable. We use our knowledge of the biological situation and our mathematical skills to obtain equations that relate the quantities. In situations where there is no physical law to guide us, we may need to collect data (either from a library or the Internet or by conducting our own experiments) and examine the data to discern patterns.

The second stage is to apply the mathematics that we know (such as the calculus that will be developed throughout this book) to the mathematical model that we have formulated in order to derive mathematical conclusions. Then, in the third stage, we take those mathematical conclusions and interpret them as information about the original biological phenomenon by way of offering explanations or making predictions. The final step is to test our predictions by checking them against new real data. If the predictions don't compare well with reality, we need to refine our model or to formulate a new model and start the cycle again.

A mathematical model is never a completely accurate representation of a physical situation—it is an idealization. Picasso once said that “art is a lie that makes us realize truth.” The same could be said about mathematical models. A good model simplifies reality enough to permit mathematical calculations, but is nevertheless realistic enough to teach us something important about the real world. Because models are simplifications, however, it is always important to keep their limitations in mind. In the end, Mother Nature has the final say.

Throughout this book we will explore a variety of different mathematical models from the life sciences. In each case we provide a brief description of the real-world problem as well as a brief mention of the real-world predictions that result from the mathematical analysis. Nevertheless, the main body of this text is designed to teach important mathematical concepts and techniques and therefore its focus is primarily on the center portion of Figure 1.

To better illustrate the entirety of the modeling process, however, we also provide a pair of *case studies in mathematical modeling*. Each case study is an extended, self-contained example of mathematical modeling from the scientific literature. In the following pages the real-world problem at the center of each case study is introduced as motivation for learning the mathematics in this book. Then, throughout subsequent chapters, these case studies are periodically revisited as we develop our mathematical skills further. In doing so, we illustrate how these mathematical skills help to address real-world problems. Additional case studies can be found on the website www.stewartcalculus.com.

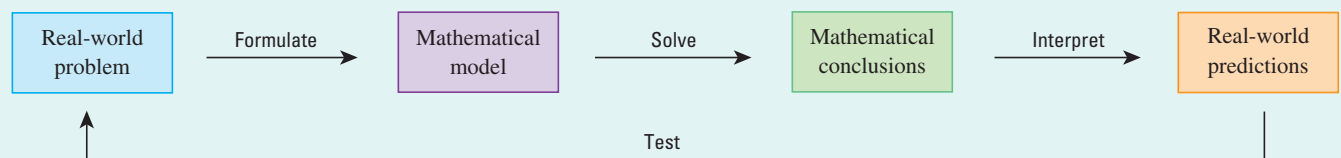
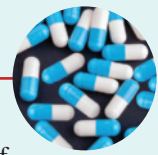

FIGURE 1 The modeling process

CASE STUDY 1 Kill Curves and Antibiotic Effectiveness



Antibiotics are often prescribed to patients who have bacterial infections. When a single dose of antibiotic is taken, its concentration at the site of infection initially increases very rapidly before slowly decaying back to zero as the antibiotic is metabolized.¹ The curve shown in Figure 1 illustrates this pattern and is referred to as the *antibiotic concentration profile*.

The clinical effectiveness of an antibiotic is determined not only by its concentration profile but also by the effect that any given concentration has on the growth rate of the bacteria population. This effect is characterized by a *dose response relationship*, which is a graph of the growth rate of the bacteria population as a function of antibiotic concentration. Bacteria typically grow well under low antibiotic concentrations, but their growth rate becomes negative (that is, their population declines) if the antibiotic concentration is high enough. Figure 2 shows an example of a dose response relationship.²

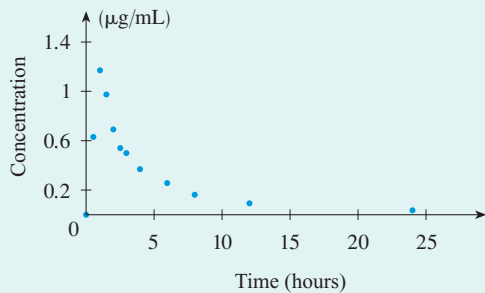

FIGURE 1

Antibiotic concentration profile in plasma of a healthy human volunteer after receiving 500 mg of ciprofloxacin

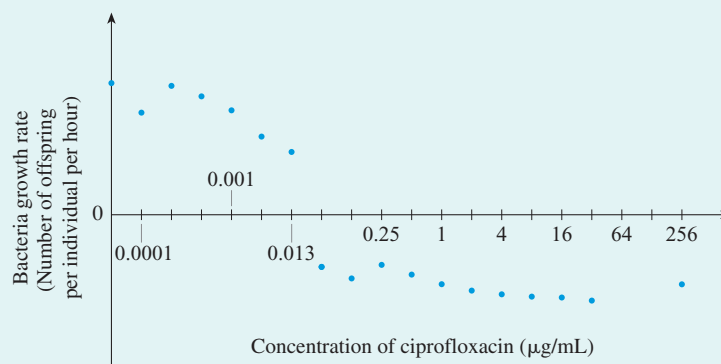

FIGURE 2

Dose response relationship for ciprofloxacin with the bacteria *E. coli*

Together, the antibiotic concentration profile and the dose response relationship determine how the bacteria population size changes over time. When the antibiotic is first administered, the concentration at the site of infection will be high and therefore the growth rate of the bacteria population will be negative (the population will decline). As the antibiotic concentration decays, the growth rate of the bacteria population eventually changes from negative to positive and the bacteria population size then rebounds. The plot of the bacteria population size as a function of time after the antibiotic is given is called the *kill curve*. An example is shown in Figure 3.

To determine how much antibiotic should be used to treat an infection, clinical researchers measure kill curves for different antibiotic doses. Figure 4 presents a family of such curves: Notice that as the dose of antibiotic increases, the bacteria population tends to decline to lower levels and to take longer to rebound.

When developing new antibiotics, clinical researchers summarize kill curves like those in Figure 4 into a simpler form to see more clearly the relationship between the

1. Adapted from S. Imre et al., "Validation of an HPLC Method for the Determination of Ciprofloxacin in Human Plasma," *Journal of Pharmaceutical and Biomedical Analysis* 33 (2003): 125–30.

2. Adapted from A. Firsov et al., "Parameters of Bacterial Killing and Regrowth Kinetics and Antimicrobial Effect Examined in Terms of Area under the Concentration-Time Curve Relationships: Action of Ciprofloxacin against *Escherichia coli* in an In Vitro Dynamic Model," *Antimicrobial Agents and Chemotherapy* 41 (1997): 1281–87.

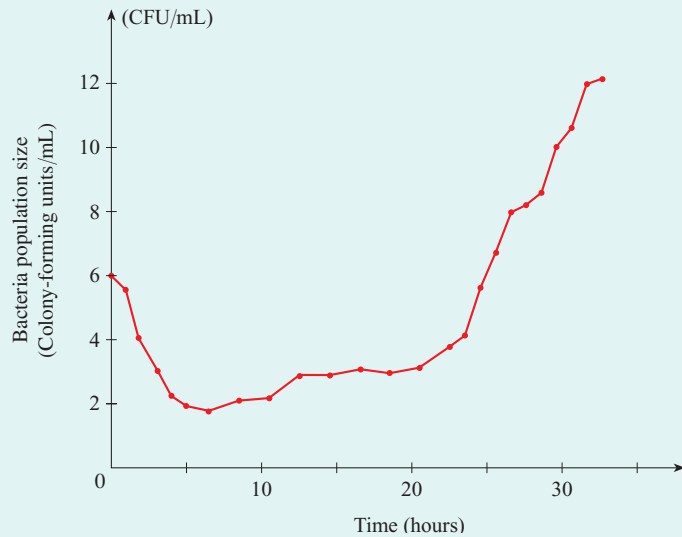

FIGURE 3
The kill curve of ciprofloxacin for *E. coli* when measured in a growth chamber. A dose corresponding to a concentration of 0.6 $\mu\text{g}/\text{mL}$ was given at $t = 0$.

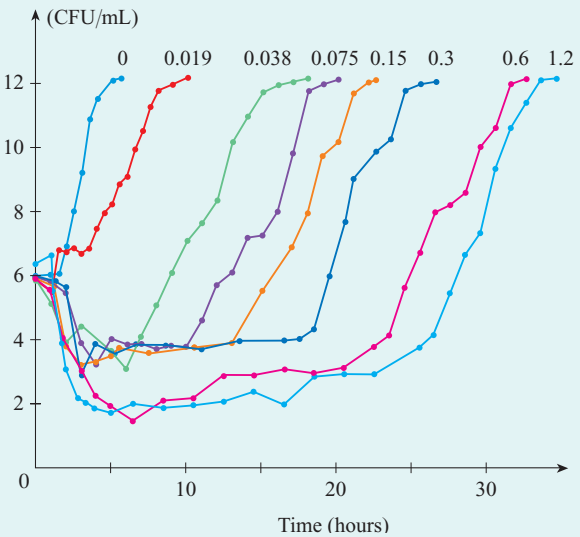

FIGURE 4
The kill curves of ciprofloxacin for *E. coli* when measured in a growth chamber. The concentration of ciprofloxacin at $t = 0$ is indicated above each curve (in $\mu\text{g}/\text{mL}$).

magnitude of antibiotic treatment and its effectiveness. This is done by obtaining both a measure of the magnitude of antibiotic treatment, from the antibiotic concentration profile underlying each kill curve, and a measure of the killing effectiveness, from the kill curve itself. These measures are then plotted on a graph of killing effectiveness against the magnitude of antibiotic treatment.

As an example, Figure 5 plots the magnitude of the drop in population size before the rebound occurs (a measure of killing effectiveness) against the peak antibiotic concentration (a measure of the magnitude of antibiotic treatment). Each of the eight colored points corresponds to the associated kill curve in Figure 4. (Peak concentration is measured in dimensionless units, as will be explained in Case Study 1a.) The points indicate that, overall, as the peak concentration increases, the magnitude of the drop in population size increases as well. This relationship can then be used by the researchers to choose an antibiotic dose that gives the peak concentration required to kill the bacterial infection.

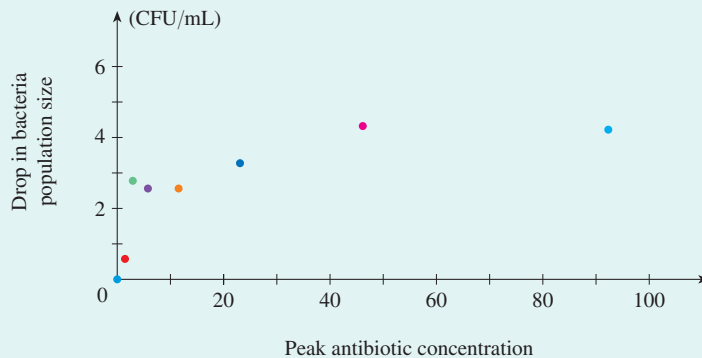

FIGURE 5

This approach for choosing a suitable antibiotic dose may seem sensible, but there are many different measures for the killing effectiveness of an antibiotic, as well as many different measures for the magnitude of antibiotic treatment. Different measures capture different properties of the bacteria–antibiotic interaction. For example, Figure 4 shows that many different antibiotic doses produce approximately the same magnitude of drop in bacteria population despite the fact that the doses result in large differences in the time necessary for population rebound to occur. Thus the magnitude of the drop in population size before rebound occurs does not completely capture the killing effectiveness of the different antibiotic doses.

For this reason, researchers typically quantify antibiotic killing effectiveness in several ways. The three most common are (1) the time taken to reduce the bacteria population to 90% of its initial value, (2) the drop in population size before rebound occurs, as was used in Figure 5, and (3) a measure that combines the drop in population size and the duration of time that the population size remains small (because effective treatment not only produces a large drop in bacteria population but maintains the population at a low level for a long period of time).

Similarly, there are many measures for the magnitude of antibiotic treatment. The most commonly used measures include (1) peak antibiotic concentration, as was used in Figure 5, (2) duration of time for which the antibiotic concentration is high enough to cause negative bacteria growth, and (3) a measure that combines both peak concentration and duration of time that the concentration remains high.

The conclusions clinical researchers obtain about suitable antibiotic doses can differ depending on which measures are used. For example, Figure 6 shows the relationship between the time taken to reduce the bacteria population to 90% of its initial value plotted against the same measure of peak antibiotic concentration as was used in Figure 5 for the kill curves shown in Figure 4. Unlike Figure 5, Figure 6 shows no consistent relationship between effectiveness (as measured by the speed of the population decline) and strength of treatment.

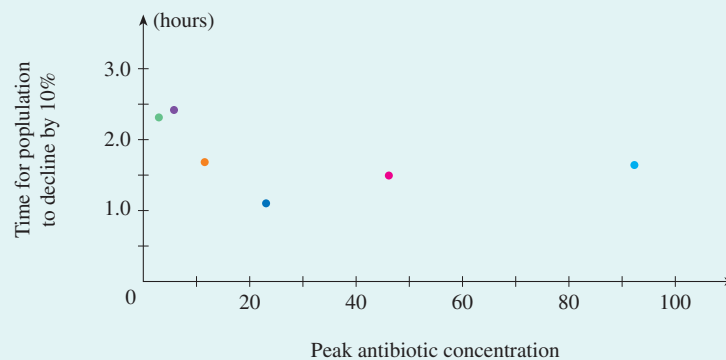

FIGURE 6

To use appropriate measures to formulate effective antibiotic doses, we therefore need to understand what determines the shape of the relationships between measures, and when and why these relationships will differ depending on the measures used. This is where mathematical modeling can play an important role: By modeling the biological processes involved, we can better understand what drives the different patterns, and we can then use models to make predictions about what we expect to observe in other situations. Making such predictions is the goal of this case study.

The order in which mathematical tools are used by researchers is not always the same as the order in which they are best learned. For example, when analyzing the problem in

this case study, researchers would first use techniques from Chapter 3 and then Chapter 6 to model the dynamics of the drug and bacteria and to quantify the strength of treatment and effectiveness of killing. They would then analyze these models using the techniques of Chapters 1 and 2.

For our learning objectives, however, this case study will be developed in the opposite order: In Case Study 1a we will use a given model for the effect of antibiotics on bacteria growth to draw conclusions about the differences in the relationships shown in Figures 5 and 6. In Case Study 1b we will begin to fill in the gaps by deriving the model used in Case Study 1a. In Case Study 1c we will continue to fill in gaps from Case Study 1a by deriving different measures for the magnitude of antibiotic treatment. We will also show how a process called dose fractionation can be used to alter various aspects of these measures. Finally, in Case Study 1d we will use the model derived in Case Study 1b to make new predictions about the effectiveness of antibiotics and compare these predictions to data.



By definition, a parasite has an antagonistic relationship with the host it infects. For this reason we might expect the host to evolve strategies that resist infection, and the parasite to evolve strategies that subvert this host resistance. The end result might be a never-ending coevolutionary cycle between host and parasite, with neither party gaining the upper hand. Indeed, we might expect the ability of the parasite to infect the host to remain relatively unchanged over time despite the fact that both host and parasite are engaged in cycles of evolutionary conflict beneath this seemingly calm surface.

This is an intriguing idea, but how might it be examined scientifically? Ideally we would like to hold the parasite fixed in time and see if its ability to infect the host declines as the host evolves resistance. Alternatively, we might hold the host fixed in time and see if the parasite's ability to infect the host increases as it evolves ways to subvert the host's current defenses.

Another possibility would be to challenge the host with parasites from its evolutionary past. In this case we might expect the host to have the upper hand, since it will have evolved resistance to these ancestral parasites. Similarly, if we could challenge the host with parasites from its evolutionary future, then we might expect the parasite to have the upper hand, since it will have evolved a means of subverting the current host defenses.

Exactly this sort of "time-travel" experiment has been done using a bacterium as the host and a parasite called a *bacteriophage*.¹ To do so, researchers let the host and parasite coevolve together for several generations. During this time, they periodically took samples of both the host and the parasite and placed the samples in a freezer. After several generations they had a frozen archive of the entire temporal sequence of hosts and parasites. The power of their approach is that the host and parasite could then be resuscitated from this frozen state. This allowed the researchers to resuscitate hosts from one point in time in the sequence and then challenge them with resuscitated parasites from their past, present, and future.

The results of one such experiment are shown in Figure 1. The data show that hosts are indeed better able to resist parasites from their past, but are much more susceptible to infection by those from their future.

This is a compelling experiment but, by its very nature, it was conducted in a highly artificial setting. It would be interesting to somehow explore this idea in a natural host-parasite system. Incredibly, researchers have done exactly that with a species of freshwater crustacean and its parasite.²

Daphnia are freshwater crustacea that live in many lakes. They are parasitized by many different microbes, including a species of bacteria called *Pasteuria ramosa*. These two organisms have presumably been coevolving in lakes for many years, and the question is whether or not they too have been undergoing cycles of evolutionary conflict.

Occasionally, both the host and the parasite produce dormant offspring (called propagules) that sink to the bottom of the lake. As time passes, sediment containing these propagules accumulates at the bottom of the lake. Over many years this sediment builds up, providing a historical record of the host and parasite (see Figure 2). A sediment core can then be taken from the bottom of the lake, giving an archive of the temporal sequence of hosts and parasites over evolutionary time (see Figure 3). And again, as with the first experiment, these propagules can be resuscitated and infection experiments conducted.

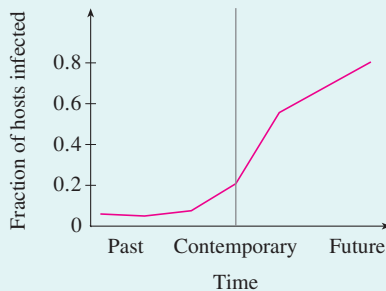

FIGURE 1
Horizontal axis is the time from which the parasite was taken, relative to the host's point in time.

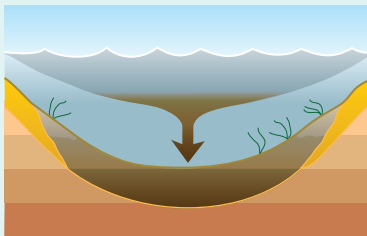
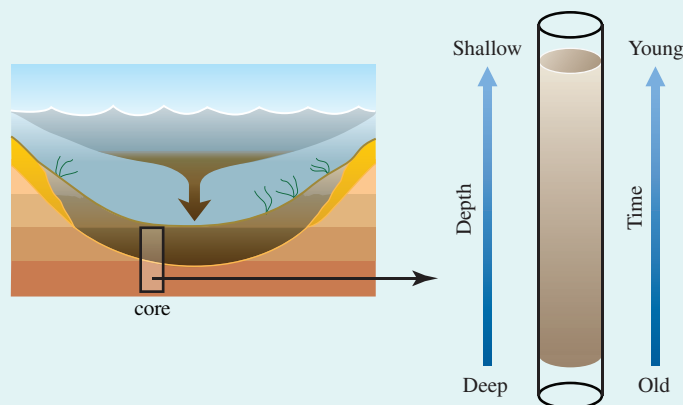
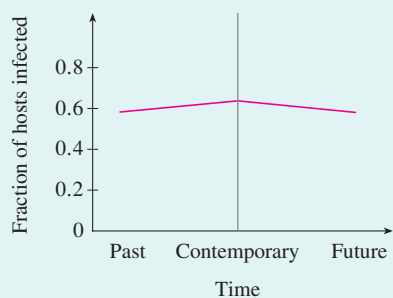

FIGURE 2
Sedimentation

1. A. Buckling et al. 2002, "Antagonistic Coevolution between a Bacterium and a Bacteriophage." *Proceedings of the Royal Society: Series B* 269 (2002): 931–36.

2. E. Decaestecker et al., "Host-Parasite 'Red Queen' Dynamics Archived in Pond Sediment." *Nature* 450 (2007): 870–73.

**FIGURE 3****FIGURE 4**

Horizontal axis is the time from which the parasite was taken, relative to the host's point in time.

Source: Adapted from S. Gandon et al., "Host-Parasite Coevolution and Patterns of Adaptation across Time and Space," *Journal of Evolutionary Biology* 21 (2008): 1861–66.

The results of the second experiment are shown in Figure 4: The pattern is quite different from that in Figure 1, with hosts being able to resist parasites from their past and their future, more than those taken from a contemporary point in time.

How can we understand these different patterns? Is it possible that this *Daphnia*–parasite system is also undergoing the same dynamic as the bacteriophage system, but that the different pattern seen in this experiment is simply due to differences in conditions? More generally, what pattern would we expect to see in the *Daphnia* experiment under different conditions if such coevolutionary conflict is actually occurring? To answer these questions we need a more quantitative approach. This is where mathematical modeling comes into play.

Models begin by simplifying reality (recall that a model is “a lie that makes us realize truth”). Thus, let’s begin by supposing that there are only two possible host genotypes (A and a) and two possible parasite genotypes (B and b). Suppose that parasites of type B can infect only hosts of type A, while parasites of type b can infect only hosts of type a. Although we know reality is likely more complicated than this, these simplifying assumptions capture the essential features of an antagonistic interaction between a host and its parasite.

Under these assumptions we might expect parasites of type B to flourish when hosts of type A are common. But this will then give an advantage to hosts of type a, since they are resistant to type B parasites. As a result, type a hosts will then increase in frequency. Eventually, however, this will favor the spread of type b parasites, which then sets the stage for the return of type A hosts. At this point we might expect the cycle to repeat.

In this case study you will construct and analyze a model of this process. As is common in modeling, the order in which different mathematical tools are used by scientists is not always the same as the order in which they are best learned. For example, when scientists worked on this question they first used techniques from Chapter 7 and then Chapter 10 to formulate the model. They then used techniques from Chapter 6 and then Chapter 2 to draw important biological conclusions.³ To fit with our learning objectives, however, this case study is developed the other way around. Following Chapter 2, in Case Study 2a, we will use given functions to draw biological conclusions about host–parasite coevolution. Following Chapter 6, in Case Study 2b, we will then begin to fill in the gaps by deriving these functions from the output of a model. Following Chapter 7, in Case Study 2c, we will then formulate this model explicitly, and following Chapter 10, in Case Study 2d, we will derive the output of the model that is used in Case Study 2b.

3. S. Gandon et al., “Host–Parasite Coevolution and Patterns of Adaptation across Time and Space,” *Journal of Evolutionary Biology* 21 (2008): 1861–66.

Functions and Sequences

1

Often a graph is the best way to represent a function because it conveys so much information at a glance. The electrocardiograms shown are graphs that exhibit electrical activity in various parts of the heart (See Figure 1 on page 2.) They enable a cardiologist to view the heart from different angles and thereby diagnose possible problems.

© Vydrin / Shutterstock.com



1.1 Four Ways to Represent a Function

1.2 A Catalog of Essential Functions

1.3 New Functions from Old Functions

PROJECT: The Biomechanics of Human Movement

1.4 Exponential Functions

1.5 Logarithms; Semilog and Log-Log Plots

PROJECT: The Coding Function of DNA

1.6 Sequences and Difference Equations

PROJECT: Drug Resistance in Malaria

CASE STUDY 1a: Kill Curves and Antibiotic Effectiveness

THE FUNDAMENTAL OBJECTS THAT WE deal with in calculus are functions. This chapter prepares the way for calculus by discussing the basic ideas concerning functions, their graphs, and ways of transforming and combining them. We stress that a function can be represented in different ways: by an equation, in a table, by a graph, or in words. We look at the main types of functions that occur in calculus and describe the process of using these functions as mathematical models in biology. A special type of function, namely a sequence, is often used in modeling biological phenomena. In particular, we study recursive sequences, also called difference equations, because they are useful in describing cell division, insect populations, and other biological processes.

1.1 Four Ways to Represent a Function

Functions arise whenever one quantity depends on another. Consider the following four situations.

Table 1

Year	Population (millions)
1900	1650
1910	1750
1920	1860
1930	2070
1940	2300
1950	2560
1960	3040
1970	3710
1980	4450
1990	5280
2000	6080
2010	6870

A. The area A of a circle depends on the radius r of the circle. The rule that connects r and A is given by the equation $A = \pi r^2$. With each positive number r there is associated one value of A , and we say that A is a *function* of r .

B. The human population of the world P depends on the time t . Table 1 gives estimates of the world population $P(t)$ at time t , for certain years. For instance,

$$P(1950) \approx 2,560,000,000$$

But for each value of the time t there is a corresponding value of P , and we say that P is a function of t .

C. The cost C of mailing an envelope depends on its weight w . Although there is no simple formula that connects w and C , the post office has a rule for determining C when w is known.

D. Figure 1 shows a graph called an electrocardiogram (ECG), or rhythm strip, one of 12 produced by an electrocardiograph. It measures the electric potential V (measured in millivolts) as a function of time in a certain direction (toward the positive electrode of a lead) corresponding to a particular part of the heart. For a given value of the time t , the graph provides a corresponding value of V .



FIGURE 1

Electrocardiogram

Source: Courtesy of Dr. Brian Gilbert

Each of these examples describes a rule whereby, given a number (r , t , w , or t), another number (A , P , C , or V) is assigned. In each case we say that the second number is a function of the first number.

Definition A **function** f is a rule that assigns to each element x in a set D exactly one element, called $f(x)$, in a set E .



FIGURE 2
Machine diagram for a function f

We usually consider functions for which the sets D and E are sets of real numbers. The set D is called the **domain** of the function. The number $f(x)$ is the **value of f at x** and is read “ f of x .” The **range** of f is the set of all possible values of $f(x)$ as x varies throughout the domain. A symbol that represents an arbitrary number in the *domain* of a function f is called an **independent variable**. A symbol that represents a number in the *range* of f is called a **dependent variable**. In Example A, for instance, r is the independent variable and A is the dependent variable.

It’s helpful to think of a function as a **machine** (see Figure 2). If x is in the domain of the function f , then when x enters the machine, it’s accepted as an input and the machine produces an output $f(x)$ according to the rule of the function. Thus we can think of the domain as the set of all possible inputs and the range as the set of all possible outputs.

The preprogrammed functions in a calculator are good examples of a function as a machine. For example, the square root key on your calculator computes such a function. You press the key labeled $\sqrt{\quad}$ (or \sqrt{x}) and enter the input x . If $x < 0$, then x is not in the domain of this function; that is, x is not an acceptable input, and the calculator will indicate an error. If $x \geq 0$, then an *approximation* to \sqrt{x} will appear in the display. Thus the \sqrt{x} key on your calculator is not quite the same as the exact mathematical function f defined by $f(x) = \sqrt{x}$.

Another way to picture a function is by an **arrow diagram** as in Figure 3. Each arrow connects an element of D to an element of E . The arrow indicates that $f(x)$ is associated with x , $f(a)$ is associated with a , and so on.

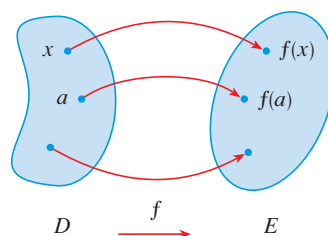

FIGURE 3
Arrow diagram for f

The most common method for visualizing a function is its graph. If f is a function with domain D , then its **graph** is the set of ordered pairs

$$\{(x, f(x)) \mid x \in D\}$$

(Notice that these are input-output pairs.) In other words, the graph of f consists of all points (x, y) in the coordinate plane such that $y = f(x)$ and x is in the domain of f .

The graph of a function f gives us a useful picture of the behavior of a function. Since the y -coordinate of any point (x, y) on the graph is $y = f(x)$, we can read the value of $f(x)$ from the graph as being the height of the graph above the point x (see Figure 4). The graph of f also allows us to picture the domain of f on the x -axis and its range on the y -axis as in Figure 5.

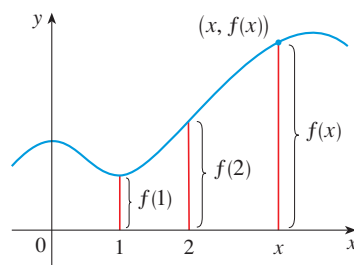

FIGURE 4

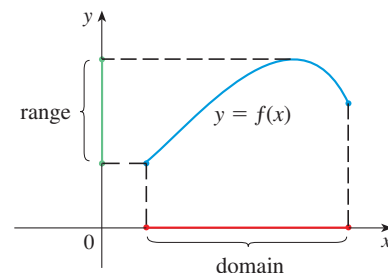

FIGURE 5

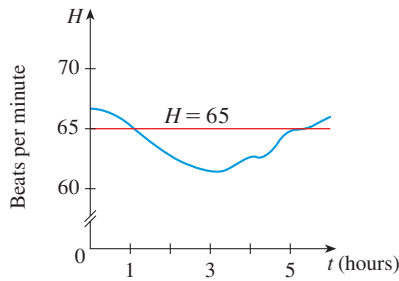

FIGURE 9

Source: Adapted from M. Brown et al., “Formulation of Long-Acting Nifedipine Tablets Influences the Heart Rate and Sympathetic Nervous System Response in Hypertensive Patients,” *British Journal of Clinical Pharmacology* 65 (2008): 646–52.

SOLUTION

(a) If $H(t)$ is the rate at time t , we estimate from the graph in Figure 9 that

$$H(2) \approx 62.5 \text{ beats/min}$$

(b) Notice that the curve lies below the line $H = 65$ for $1 \leq t \leq 5$. In other words, the heart rate is less than 65 beats/min from 1 hour to 5 hours after the tablet is administered.

EXAMPLE 4 | If $f(x) = 2x^2 - 5x + 1$ and $h \neq 0$, evaluate $\frac{f(a+h) - f(a)}{h}$.

SOLUTION We first evaluate $f(a+h)$ by replacing x by $a+h$ in the expression for $f(x)$:

$$\begin{aligned} f(a+h) &= 2(a+h)^2 - 5(a+h) + 1 \\ &= 2(a^2 + 2ah + h^2) - 5(a+h) + 1 \\ &= 2a^2 + 4ah + 2h^2 - 5a - 5h + 1 \end{aligned}$$

Then we substitute into the given expression and simplify:

$$\begin{aligned} \frac{f(a+h) - f(a)}{h} &= \frac{(2a^2 + 4ah + 2h^2 - 5a - 5h + 1) - (2a^2 - 5a + 1)}{h} \\ &= \frac{2a^2 + 4ah + 2h^2 - 5a - 5h + 1 - 2a^2 + 5a - 1}{h} \\ &= \frac{4ah + 2h^2 - 5h}{h} = 4a + 2h - 5 \end{aligned}$$

The expression

$$\frac{f(a+h) - f(a)}{h}$$

in Example 4 is called a **difference quotient** and occurs frequently in calculus. As we will see in Chapter 2, it represents the average rate of change of $f(x)$ between $x = a$ and $x = a + h$.

■ Representations of Functions

There are four possible ways to represent a function:

- verbally (by a description in words)
- numerically (by a table of values)
- visually (by a graph)
- algebraically (by an explicit formula)

If a single function can be represented in all four ways, it's often useful to go from one representation to another to gain additional insight into the function. (In Example 2, for instance, we started with algebraic formulas and then obtained the graphs.) But certain functions are described more naturally by one method than by another. With this in mind, let's reexamine the four situations that we considered at the beginning of this section.

- A. The most useful representation of the area of a circle as a function of its radius is probably the algebraic formula $A(r) = \pi r^2$, though it is possible to compile a table of values or to sketch a graph (half a parabola). Because a circle has to have a positive radius, the domain is $\{r \mid r > 0\} = (0, \infty)$, and the range is also $(0, \infty)$.

t (years since 1990)	Population (millions)
0	1650
10	1750
20	1860
30	2070
40	2300
50	2560
60	3040
70	3710
80	4450
90	5280
100	6080
110	6870

- B.** We are given a description of the function in words: $P(t)$ is the human population of the world at time t . Let's measure t so that $t = 0$ corresponds to the year 1900. The table of values of world population provides a convenient representation of this function. If we plot these values, we get the graph (called a *scatter plot*) in Figure 10. It too is a useful representation; the graph allows us to absorb all the data at once. What about a formula? Of course, it's impossible to devise an explicit formula that gives the exact human population $P(t)$ at any time t . But it is possible to find an expression for a function that *approximates* $P(t)$. In fact, using methods explained in Section 1.2, we obtain the approximation

$$P(t) \approx f(t) = (1.43653 \times 10^9) \cdot (1.01395)^t$$

Figure 11 shows that it is a reasonably good “fit.” The function f is called a *mathematical model* for population growth. In other words, it is a function with an explicit formula that approximates the behavior of our given function. We will see, however, that the ideas of calculus can be applied to a table of values; an explicit formula is not necessary.

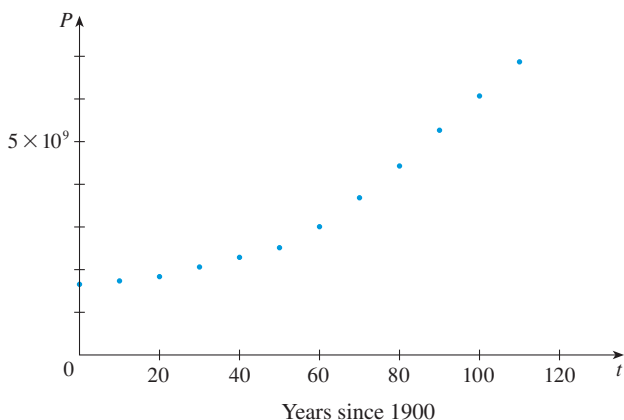

FIGURE 10

A function defined by a table of values is called a *tabular* function.

w (ounces)	$C(w)$ (dollars)
$0 < w \leq 1$	0.92
$1 < w \leq 2$	1.12
$2 < w \leq 3$	1.32
$3 < w \leq 4$	1.52
$4 < w \leq 5$	1.72
\vdots	\vdots
\vdots	\vdots
\vdots	\vdots

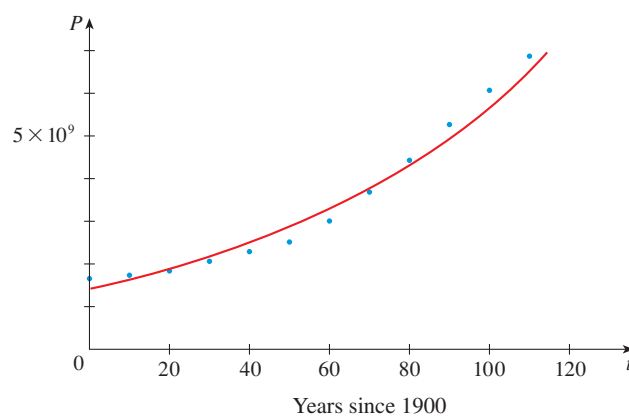

FIGURE 11

The function P is typical of the functions that arise whenever we attempt to apply calculus to the real world. We start with a verbal description of a function. Then we might be able to construct a table of values of the function, perhaps from instrument readings in a scientific experiment. Even though we don't have complete knowledge of the values of the function, we will see throughout the book that it is still possible to perform the operations of calculus on such a function.

- C.** Again the function is described in words: Let $C(w)$ be the cost of mailing a large envelope with weight w . The rule that the US Postal Service used as of 2014 is as follows: The cost is 92 cents for up to 1 oz, plus 20 cents for each additional ounce (or less) up to 13 oz. The table of values shown in the margin is the most convenient representation for this function, though it is possible to sketch a graph (see Example 11).
- D.** The graph shown in Figure 1 is the most natural representation of the voltage function $V(t)$ that reflects the electrical activity of the heart. It's true that a table of values could be compiled, and it is even possible to devise an approximate formula. But everything a doctor needs to know—amplitudes and patterns—can be seen easily from the graph. (The same is true for the patterns seen in polygraphs for lie-detection and seismographs for analysis of earthquakes.) The waves represent

the depolarization and repolarization of the atria and ventricles of the heart. They enable a cardiologist to see whether the patient has irregular heart rhythms and help diagnose different types of heart disease.

In the next example we sketch the graph of a function that is defined verbally.

EXAMPLE 5 | When you turn on a hot-water faucet, the temperature T of the water depends on how long the water has been running. Draw a rough graph of T as a function of the time t that has elapsed since the faucet was turned on.

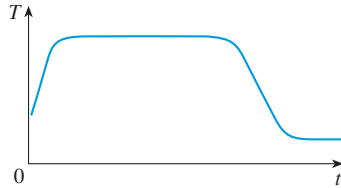

FIGURE 12

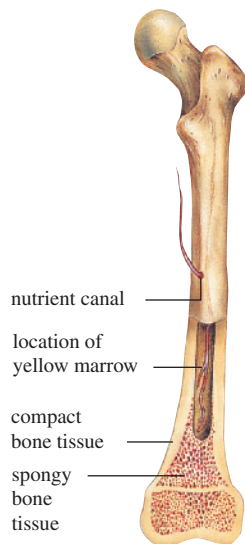

FIGURE 13

Structure of a human femur

Source: From Starr, *Biology*, 8E © 2011 Brooks/Cole, a part of Cengage Learning, Inc. Reproduced by permission. www.cengage.com/permissions

SOLUTION The initial temperature of the running water is close to room temperature because the water has been sitting in the pipes. When the water from the hot-water tank starts flowing from the faucet, T increases quickly. In the next phase, T is constant at the temperature of the heated water in the tank. When the tank is drained, T decreases to the temperature of the water supply. This enables us to make the rough sketch of T as a function of t in Figure 12.

EXAMPLE 6 | **BB** **Bone mass** A human femur (thighbone) is essentially a hollow tube filled with yellow marrow (see Figure 13). If the outer radius is r and the inner radius is r_{in} , an important quantity characterizing such bones is

$$k = \frac{r_{\text{in}}}{r}$$

The density of bone is approximately 1.8 g/cm^3 and that of marrow is about 1 g/cm^3 . For a femur with length L , express its mass as a function of k .

SOLUTION The mass of the tubular bone is obtained by subtracting the mass of the inner tube from the mass of the outer tube:

$$1.8\pi r^2 L - 1.8\pi r_{\text{in}}^2 L = 1.8\pi r^2 L - 1.8\pi (rk)^2 L$$

Similarly, the mass of the marrow is

$$1 \times (\pi r_{\text{in}}^2 L) = \pi (rk)^2 L$$

So the total mass as a function of k is

$$\begin{aligned} m(k) &= 1.8\pi r^2 L - 1.8\pi (rk)^2 L + \pi (rk)^2 L \\ &= \pi r^2 L (1.8 - 0.8k^2) \end{aligned}$$

EXAMPLE 7 | Find the domain of each function.

(a) $f(x) = \sqrt{x+2}$

(b) $g(x) = \frac{1}{x^2 - x}$

SOLUTION

(a) Because the square root of a negative number is not defined (as a real number), the domain of f consists of all values of x such that $x+2 \geq 0$. This is equivalent to $x \geq -2$, so the domain is the interval $[-2, \infty)$.

(b) Since

$$g(x) = \frac{1}{x^2 - x} = \frac{1}{x(x-1)}$$

and division by 0 is not allowed, we see that $g(x)$ is not defined when $x = 0$ or $x = 1$.

Thus the domain of g is

$$\{x \mid x \neq 0, x \neq 1\}$$

which could also be written in interval notation as

$$(-\infty, 0) \cup (0, 1) \cup (1, \infty)$$

The graph of a function is a curve in the xy -plane. But the question arises: Which curves in the xy -plane are graphs of functions? This is answered by the following test.

The Vertical Line Test A curve in the xy -plane is the graph of a function of x if and only if no vertical line intersects the curve more than once.

The reason for the truth of the Vertical Line Test can be seen in Figure 14. If each vertical line $x = a$ intersects a curve only once, at (a, b) , then exactly one function value is defined by $f(a) = b$. But if a line $x = a$ intersects the curve twice, at (a, b) and (a, c) , then the curve can't represent a function because a function can't assign two different values to a .

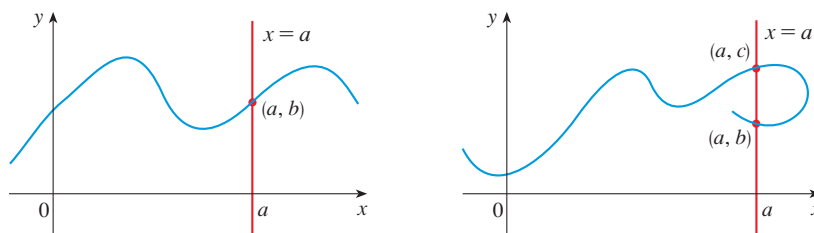

FIGURE 14

For example, the parabola $x = y^2 - 2$ shown in Figure 15(a) is not the graph of a function of x because, as you can see, there are vertical lines that intersect the parabola twice. The parabola, however, does contain the graphs of *two* functions of x . Notice that the equation $x = y^2 - 2$ implies $y^2 = x + 2$, so $y = \pm\sqrt{x + 2}$. Thus the upper and lower halves of the parabola are the graphs of the functions $f(x) = \sqrt{x + 2}$ [from Example 7(a)] and $g(x) = -\sqrt{x + 2}$. [See Figures 15(b) and (c).] We observe that if we reverse the roles of x and y , then the equation $x = h(y) = y^2 - 2$ *does* define x as a function of y (with y as the independent variable and x as the dependent variable) and the parabola now appears as the graph of the function h .

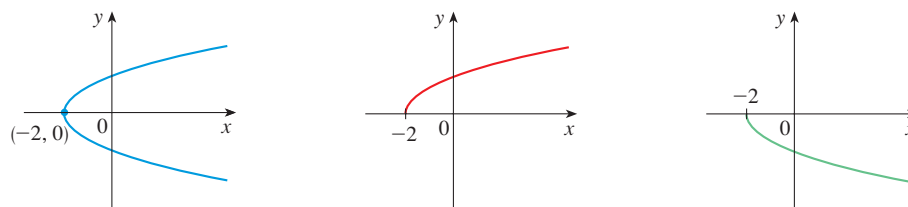

FIGURE 15

(a) $x = y^2 - 2$

(b) $y = \sqrt{x + 2}$

(c) $y = -\sqrt{x + 2}$

■ Piecewise Defined Functions

The functions in the following four examples are defined by different formulas in different parts of their domains. Such functions are called **piecewise defined functions**.

EXAMPLE 8 | A function f is defined by

$$f(x) = \begin{cases} 1 - x & \text{if } x \leq -1 \\ x^2 & \text{if } x > -1 \end{cases}$$

Evaluate $f(-2)$, $f(-1)$, and $f(0)$ and sketch the graph.

SOLUTION Remember that a function is a rule. For this particular function the rule is the following: First look at the value of the input x . If it happens that $x \leq -1$, then the value of $f(x)$ is $1 - x$. On the other hand, if $x > -1$, then the value of $f(x)$ is x^2 .

$$\text{Since } -2 \leq -1, \text{ we have } f(-2) = 1 - (-2) = 3.$$

$$\text{Since } -1 \leq -1, \text{ we have } f(-1) = 1 - (-1) = 2.$$

$$\text{Since } 0 > -1, \text{ we have } f(0) = 0^2 = 0.$$

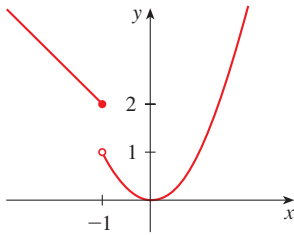

FIGURE 16

How do we draw the graph of f ? We observe that if $x \leq -1$, then $f(x) = 1 - x$, so the part of the graph of f that lies to the left of the vertical line $x = -1$ must coincide with the line $y = 1 - x$, which has slope -1 and y -intercept 1 . If $x > -1$, then $f(x) = x^2$, so the part of the graph of f that lies to the right of the line $x = -1$ must coincide with the graph of $y = x^2$, which is a parabola. This enables us to sketch the graph in Figure 16. The solid dot indicates that the point $(-1, 2)$ is included on the graph; the open dot indicates that the point $(-1, 1)$ is excluded from the graph. ■

The next example of a piecewise defined function is the absolute value function. Recall that the **absolute value** of a number a , denoted by $|a|$, is the distance from a to 0 on the real number line. Distances are always positive or 0 , so we have

$$|a| \geq 0 \quad \text{for every number } a$$

For example,

$$|3| = 3 \quad |-3| = 3 \quad |0| = 0 \quad |\sqrt{2} - 1| = \sqrt{2} - 1 \quad |3 - \pi| = \pi - 3$$

In general, we have

$$\begin{cases} |a| = a & \text{if } a \geq 0 \\ |a| = -a & \text{if } a < 0 \end{cases}$$

(Remember that if a is negative, then $-a$ is positive.)

EXAMPLE 9 | Sketch the graph of the absolute value function $f(x) = |x|$.

SOLUTION From the preceding discussion we know that

$$|x| = \begin{cases} x & \text{if } x \geq 0 \\ -x & \text{if } x < 0 \end{cases}$$

Using the same method as in Example 8, we see that the graph of f coincides with the line $y = x$ to the right of the y -axis and coincides with the line $y = -x$ to the left of the y -axis (see Figure 17). ■

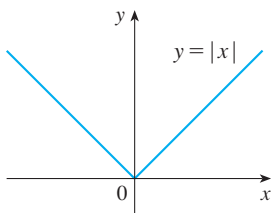

FIGURE 17